



Industrial Control Transformers

Section



Industrial Control Transformers provide a low and safe control voltage for the operation of electromagnetic devices, such as motor starters, contactors, solenoids and timers...or other loads requiring above average voltage regulation when actuated.

Selection Steps	72-73
TA Series Open Core and Coil	74
Primary and Secondary Fuse Information	75-76
Selection Charts	80-87
Wiring Diagrams and Dimensions	88
TB Series Open Core and Coil	77
Primary and Secondary Fuse Information	78-79
Selection Charts	80-87
Wiring Diagrams and Dimensions	89
Harsh Environments Control Transformers	90
AC/CE Series Encapsulated Transformers	91-92
Selection Charts	93-96
Primary and Secondary Fuse Information	97-98
Wiring Diagrams and Dimensions	98-99
Finger Guard Industrial Control Transformers	100
Selection Charts	101-102
Primary and Secondary Fuse Information	102-103
Wiring Diagrams and Dimensions	104

SELECTING INDUSTRIAL CONTROL TRANSFORMERS

To make the proper transformer selection, the load must be completely analyzed, which involves every electrically energized component in the control circuit.

All electromagnetic control devices have two current requirements; the first to energize the coil; the second to maintain the contact for a definite period of time. The initial energizing of the coil, which takes 5 to 20 milliseconds, requires many times more current than normal. This is referred to as volt-ampere inrush, which is immediately followed by the sealed volt-amperes—the amount of current required to hold the contact in the circuit.

Five step selection

1. Determine the voltage and frequency of supply circuit: Example: 460 Volts, 60 Hz.
2. Determine the total inrush VA of the control circuits from the manufacturer's data or the contactor data table. Do not neglect the current requirements of indicating lights and timing devices that do not have an inrush VA but are energized at the same time as the other components in the circuit. Their total VA should be added to the total inrush VA.
3. Refer to the regulation data chart. If the supply circuit voltage (Step 1) is reasonably stable and fluctuates no more than $\pm 5\%$, refer to the 90% Secondary Voltage column. If it fluctuates as much as $\pm 10\%$, refer to the 95% Secondary Voltage column. Go down the column you have selected until you arrive at the inrush VA closest to, but not less than, the inrush VA of your control circuit.
4. Read to the far left side of the chart and you have selected the continuous nominal VA rating of the transformer needed. The secondary voltage that will be delivered under inrush conditions will be either 85%, 90%, or 95% of the rated secondary voltage depending on the column selected from the regulation data chart. The total sealed VA of the control circuit must not exceed the nominal VA rating of the transformer selected from the manufacturer's data or the contactor's data table.
5. Refer to the specification tables on the following pages to select a transformer according to the required continuous nominal VA and primary/secondary voltages.

Table 1 Inrush VA

Normal VA Rating	Inrush VA @ 20% and 40% Power Factor					
	85% Secondary Voltage		90% Secondary Voltage		95% Secondary Voltage	
	20% P.F.	40% P.F.	20% P.F.	40% P.F.	20% P.F.	40% P.F.
50	362	224	289	179	217	134
75	579	354	462	283	345	211
100	839	522	664	413	489	304
150	1326	842	1003	637	679	431
250	3447	2281	2462	1629	1477	977
300	3894	2618	2812	1890	1731	1163
350	5418	3689	3870	2635	2322	1581
500	6496	4575	4691	3304	2887	2033
750	8377	5811	5913	4102	3449	2393
1000	11329	9005	7789	6191	4248	3377
1500	25519	18803	18013	13273	10508	7742
2000	28178	21600	19372	14850	10566	8100
3000	34797	28391	24562	20041	14328	11690
5000	138500	84542	100000	61058	61550	37574

① Data is most current at time of printing. Contact individual manufacturer for updates.

Table 2 Typical Magnetic Motor Starter and Contractor Data ① 60 Hz, 120 Volt, 3-Pole

Contractor		N.E.M.A. Size								
		00	0	1	2	3	4	5	A	L
Allen Bradley	500 Series	—	192	192	240	660	1225	2040	1490	VA Inrush
		—	29	29	29	45	69	110	96	VA Sealed
	K Series	53	110	175	240	580	1000	1950		VA Inrush
		15	20	22	31	43	65	98		VA Sealed
ASEA	Heavy	5	85	100	150	490	900	1200		VA Inrush
	Duty	9	9	11.5	15	35	55	65		VA Sealed
Furnas		218	218	218	218	310	957	1518		VA Inrush
		25	25	25	25	26	75	116		VA Sealed
General Electric		151	151	151	528	1152	1248	2580		VA Inrush
		24	24	24	60	83	86	191		VA Sealed
Joslyn Clark		210	210	210	210	724	880	1790		VA Inrush
		18	18	18	18	30	39	295		VA Sealed
Siemens-Allis		76	76	76	194	365	530	1630		VA Inrush
		12	12	12	21	35	40	110		VA Sealed
Square D		165	245	245	311	700	1185	2970		VA Inrush
		33	27	27	37	46	85	212		VA Sealed
Westinghouse		160	160	160	160	625	625	1700		VA Inrush
		25	25	25	25	50	50	180		VA Sealed
Cutler Hammer (Citation Line)	A1 Series	87	103	103	—	—	—	1158		VA Inrush
		15	20	20	—	—	—	100		VA Sealed
	B1 Series	102	103	103	140	390	1158	1158		VA Inrush
		13	20	20	24	50	100	100		VA Sealed

① Data is most current at time of printing. Contact individual manufacturer for updates.



Industrial control transformers are used to reduce supply voltages to 230 V or lower for the operation of electromagnetic devices such as contactors, solenoids, relays, and timers. They are especially designed to accommodate the momentary current inrush caused when electromagnetic components are energized without sacrificing secondary voltage stability beyond practical limits.

Acme Industrial Control Transformers are dry-type, step-down transformers with the secondary control circuit isolated from the primary line circuit to assure maximum safety.

Voltage regulation of Acme Industrial Control Transformers exceeds standards recommended by the National Electrical Manufacturers Association. Secondary circuit voltage drop between no-load and momentary overload remains exceptionally low. This excellent secondary circuit voltage regulation assures reliable operation of electromagnetic components and may permit the use of a smaller and less expensive industrial control transformer.

Features

- Constructed with high quality silicon steel lamination to minimize core losses and increase efficiency.
- Designs incorporate precision wound coils for improved regulation.
- Primary fuse blocks and secondary fuse kits available and easily adaptable.
- Series-parallel connecting links save wiring and labor costs.
- Sturdy phenolic terminal panel protects the coil from foreign objects and mechanical damage.
- Copper windings on all groups.
- 130°C Insulation class. 80°C temperature rise.
- Wire retention on both primary and secondary terminals.
- Mounting plate adapts to various mounting dimensions.
- Voltage regulation exceeds NEMA requirements.
- UL Listed, CSA Certified.
- Attractive finish, nameplate, and design features enhance the end product.

Acme Industrial Control Transformers Meet or Exceed UL, CSA, NEMA & ANSI – Acme

Industrial Control Transformers 50 through 5000 VA are UL Listed, File E79947 and CSA certified, File 7357.

Laminations—High-permeability silicon steel continuously annealed to minimize core losses.

Magnet Wire—Copper magnet wire is coated with high temperature-resisting insulating film.

Coils—Precision wound by machine; total turns per coil automatically counted.

Mounting—Heavy steel mounting plates add strength to core construction and provide firm mounting, slotted to facilitate installation.

Terminal Boards—Sturdy phenolic terminal boards.

Sizing Primary Fuses:

Primary Amps < 2, fuse size is 300% of rated primary current.

Primary Amps 2 < 9, fuse size is 167% of rated primary current.

Primary Amps ≥ 9, fuse size is 125% of rated primary current.

Sizing Secondary Fuses:

Secondary Amps < 9, fuse size is 167% of rated secondary current.

Secondary Amps ≥ 9, fuse size is 125% of rated secondary current.



Primary Fuse Kit with Snap-on Secondary Fuse Block



Jumper Link Connections



Secondary Fuse Clips



Integrally Mounted Fuse Blocks

TA SERIES PRIMARY FUSE KITS

Type PL112700 Through PL112705:

Using 2 Class CC Dual Element Fuses (not supplied)

- Meets NEC Article 450 and UL-508 requirements.
- For use with class “CC” fuses.
- Eliminates remote mounting of primary overcurrent protection.
- Covered by Acme Electric 10-year limited warranty.

Field installation is fast and easy. Simply loosen the mounting hardware (Fig. 1), slide the bracket over the transformer and re-tighten the mounting hardware. Make the proper connections with the factory furnished jumpers (Fig. 2) and your unit is ready for operation.

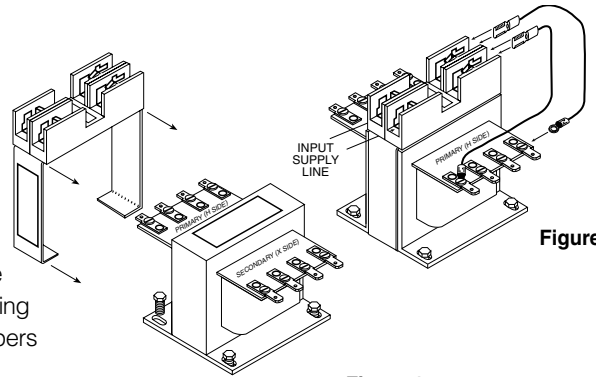

Figure 2

Figure 1

INSTRUCTIONS FOR TA SERIES PRIMARY FUSE KITS

Type PL112706 Through PL112707: 3000 - 5000 VA

Using 2 Class CC Dual Element Fuses (not supplied)

1. To mount the primary fuse kit bracket, remove the two 1/4" (.64 cm) sheet metal screws on the terminal panel on the primary (H side) of the transformer.
2. Place the slots in the fuse kit mounting bracket over the holes in the terminal and mounting bracket. To secure the fuse kit, reinsert the two 1/4" (.64 cm) sheet metal screws and tighten securely.
3. Tighten all mounting screws securely—this will secure the mounting bracket.
4. Attach the female quick connect of the jumpers supplied with the fuse kit to male quick connects on the right side of the fuse blocks—one jumper to each of the blocks.
5. Connect the ring terminal of the jumpers to the appropriate screw terminals of the transformers primary (H side). Refer to the transformer name plate for proper terminal connections.
6. Connect primary supply line leads to the screw terminals on the left side of the block—one line lead to each of the fuse blocks.

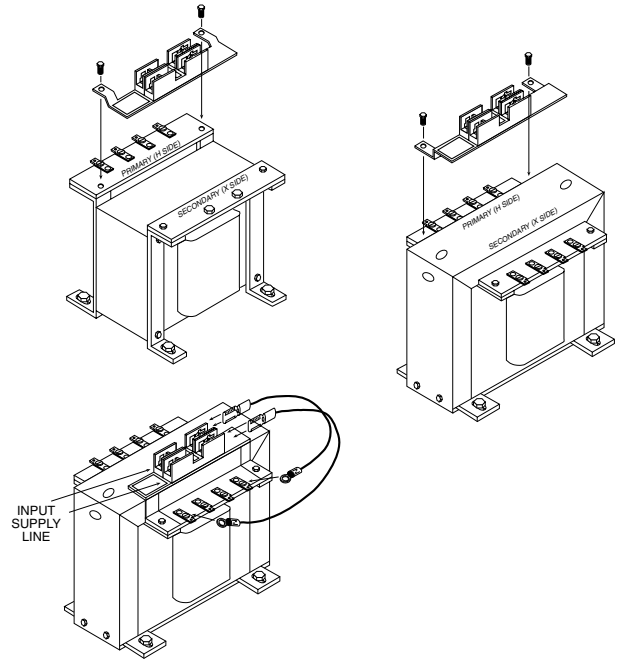

PRIMARY FUSE SIZING CHART ①

VA	120V	208V	230V	240V	277V	380V	416V	440V	460V	480V	550V	600V
50	1.2	0.6	0.6	0.6	0.6	0.3	0.3	0.3	0.3	0.3	0.3	0.3
75	1.9	1.0	1.0	1.0	0.8	0.6	0.6	0.6	0.5	0.5	0.4	0.4
100	2.5	1.5	1.3	1.3	1.0	0.8	0.8	0.6	0.6	0.6	0.6	0.5
150	3.8	2.0	2.0	1.9	1.5	1.2	1.2	1.0	1.0	1.0	0.8	0.8
250	3.5	3.5	3.5	3.0	3.0	2.0	1.8	1.8	1.5	1.5	1.4	1.2
300	4.0	4.0	4.0	3.5	3.0	2.5	2.5	2.0	2.0	1.9	1.5	1.5
350	5.0	5.0	4.5	4.0	4.0	2.5	2.5	2.5	2.0	2.0	1.9	1.8
500	7.0	4.0	3.5	3.5	5.5	4.0	3.5	3.5	3.5	3.0	3.0	2.5
750	10.0	6.0	5.5	5.0	4.5	6.0	5.5	5.0	5.0	5.0	4.0	4.0
1000	15.0	8.0	7.0	7.0	6.0	4.5	4.0	3.5	3.5	3.5	5.5	5.0
1500	20.0	12.0	12.0	12.0	10.0	7.0	6.0	6.0	5.5	5.5	5.0	4.5
2000	25.0	12.0	15.0	15.0	12.0	9.0	8.0	8.0	7.5	7.0	6.0	6.0
3000	30.0	20.0	20.0	20.0	15.0	15.0	12.0	12.0	12.0	12.0	10.0	9.0
5000	—	30.0	30.0	30.0	25.0	20.0	15.0	15.0	15.0	15.0	12.0	15.0

① Fuse size based on time delay class CC fuses.

NOTE: Bold lines indicate changes in the percent of rated current used to calculate fuse sizes in accordance with article 450 of the NEC.

TA SERIES SECONDARY FUSE KITS

Type PL112700 Through PL112705:

Type PL112600, 601, 602: Use Dual Element Slow-Blow Fuse

- Mount secondary fuse clips on terminals X1 and F or F1 using the screws supplied with the transformer.
- Connect secondary load lines to terminals X2 and F or F2.
- Use dual-element slow-blowing fuses such as Bussmann MFG., Fusetron Type FNM, Littelfuse or Shawmut (not supplied with fuse kits).

INSTRUCTIONS FOR TA SERIES SECONDARY FUSE KITS

Type PL112603: use dual element slow-blow fuse 13/32" x 1-1/2" (1.0 x 3.8 cm)

1. To attach secondary fuse kit PL-112603 to primary fuse kits PL112700 thru PL112707 snap the secondary single pole fuse block onto the unlabeled side of the primary double pole fuse block. (See Figure 1)
2. Install the fuse kits as instructed under the secondary fuse kit instructions on page 76.
3. Select the appropriate pair of jumpers for making the connections between the secondary fuse block and the secondary (X-side) of the transformer.
4. Connect the female quick-connect of the jumpers supplied to one of the male quick-connects of the secondary fuse block - one jumper to each end of the fuse block. (See Figure 2)
5. Connect the ring terminal of the jumpers supplied to screw terminals X1 and F or F1 on the secondary (X-side) of the transformer.
6. Connect secondary load lines to terminals X2 and F or F2.

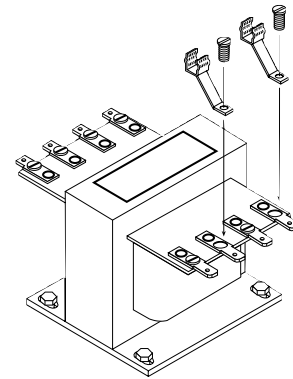

PL112600/601 Fuse Kit

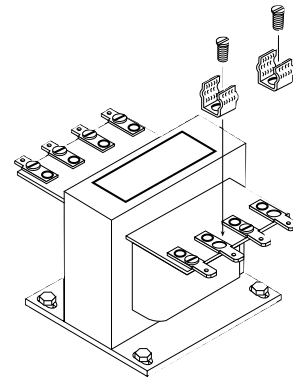

PL112602 Fuse Kit

Jumper Link Connections

- Group A Series: 240 V parallel: 120 V
- Group B Series: 480 V parallel: 240 V
- Group F series: 230 V parallel: 115 V
- Group I Series: 24 V parallel: 12 V
- Group J Series: 480 V & 240 V: 240 V & 120 V
- Group K Series: 240 V: 120 V

Exception: 150 VA transformer TA232404 does not have quick connect terminals.

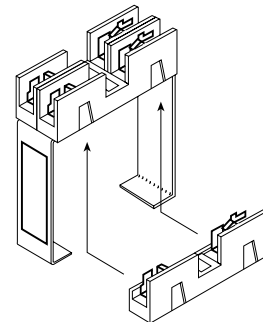

Figure 1

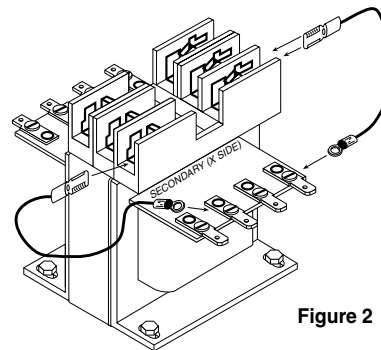
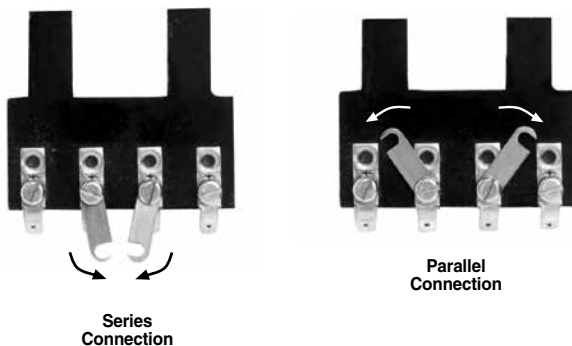

Figure 2



Acme's TB Series Industrial Control Transformers are especially designed to accommodate the momentary current inrush caused when electromagnetic components are energized... without sacrificing secondary voltage stability beyond practical limits.

Acme's TB Series transformers are dry-type, step-down transformers with the secondary control circuit isolated from the primary line circuit to assure maximum safety.

Voltage regulation of Acme's TB Series transformers exceeds standards recommended by the National Electrical Manufacturers Association. Secondary circuit voltage drop between no-load and momentary overload remains exceptionally low. This excellent secondary circuit voltage regulation assures reliable operation of electromagnetic components and may permit the use of a smaller and less expensive industrial control transformer.

Features

- 600 volt class and below.
- 50–1000 VA, 50/60 Hz.
- 80°C temperature rise, 130°C insulation class.
- Constructed with high quality silicon steel lamination to minimize core losses and increase efficiency.
- Designs incorporate precision split bobbin wound coils for improved regulation.
- Primary fuse blocks and secondary fuse kits available and easily adaptable.
- Series-parallel connecting links save wiring and labor costs.
- Terminal blocks allow full access for ring terminals for easy installation even with solid strand conductors.
- Integrally molded terminal blocks with isolation barriers to prevent arc over.
- Footprint matches TA Series for easy interchangeability.
- Copper windings on all groups.
- Heavy gauge steel mounting plate adapts to various mounting dimensions.
- Voltage regulation exceeds NEMA requirements.
- UL Listed and CSA Certified.
- Meets or exceeds UL, CSA, NEMA, ANSI and OSHA Standards.
- Ten-year limited warranty.

Applications

- Motor Starters
- Contactors
- Solenoids
- Timer Circuits
- Relays
- Control Panels
- Robotics



TB SERIES PRIMARY FUSE KITS

**Type PL112700 Through PL112705:
Using 2 Class CC Dual Element Fuses (not supplied)**

- Meets NEC Article 450 and UL -508 requirements.
- For use with class “CC” fuses.
- Eliminates remote mounting of primary overcurrent protection.
- Covered by Acme Electric 10-year limited warranty.

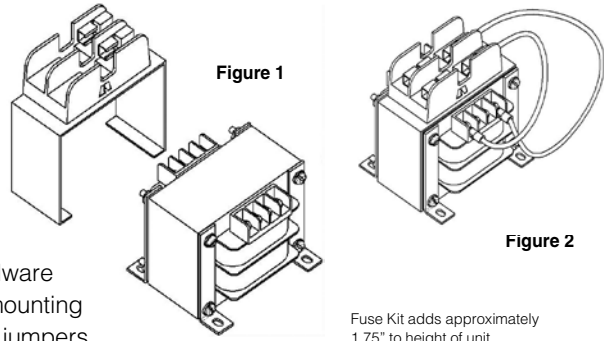

Field installation is fast and easy. Simply loosen the mounting hardware (Fig. 1), slide the bracket over the transformer and re-tighten the mounting hardware. Make the proper connections with the factory furnished jumpers (Fig. 2) and your unit is ready for operation.

Fuse Kit adds approximately 1.75" to height of unit.

PRIMARY FUSE SIZING CHART ①

VA	120V	208V	230V	240V	277V	380V	416V	440V	460V	480V	550V	600V
50	1.2	0.6	0.6	0.6	0.6	0.3	0.3	0.3	0.3	0.3	0.3	0.3
75	1.9	1.0	1.0	1.0	0.8	0.6	0.6	0.6	0.5	0.5	0.4	0.4
100	2.5	1.5	1.3	1.3	1.0	0.8	0.8	0.6	0.6	0.6	0.6	0.5
150	3.8	2.0	2.0	1.9	1.5	1.2	1.2	1.0	1.0	1.0	0.8	0.8
250	3.5	3.5	3.5	3.0	3.0	2.0	1.8	1.8	1.5	1.5	1.4	1.2
300	4.0	4.0	4.0	3.5	3.0	2.5	2.5	2.0	2.0	1.9	1.5	1.5
350	5.0	5.0	4.5	4.0	4.0	2.5	2.5	2.5	2.0	2.0	1.9	1.8
500	7.0	4.0	3.5	3.5	5.5	4.0	3.5	3.5	3.5	3.0	3.0	2.5
750	10.0	6.0	5.5	5.0	4.5	6.0	5.5	5.0	5.0	5.0	4.0	4.0
1000	15.0	8.0	7.0	7.0	6.0	4.5	4.0	3.5	3.5	3.5	5.5	5.0
1500	20.0	12.0	12.0	12.0	10.0	7.0	6.0	6.0	5.5	5.5	5.0	4.5
2000	25.0	12.0	15.0	15.0	12.0	9.0	8.0	8.0	7.5	7.0	6.0	6.0
3000	30.0	20.0	20.0	20.0	15.0	15.0	12.0	12.0	12.0	12.0	10.0	9.0
5000	—	30.0	30.0	30.0	25.0	20.0	15.0	15.0	15.0	15.0	12.0	15.0

① Fuse size based on time delay class CC fuses.

NOTE: Bold lines indicate changes in the percent of rated current used to calculate fuse sizes in accordance with article 450 of the NEC.

SECONDARY FUSE SIZING CHART

VA	24V	85V	91V	99V	100V	110V	115V	120V	125V	130V
50 VA	3.2	0.9	0.9	0.8	0.8	0.7	0.7	0.6	0.6	0.6
75 VA	5.0	1.4	1.2	1.2	1.2	1.0	1.0	1.0	1.0	0.8
100 VA	6.0	1.5	1.5	1.5	1.5	1.5	1.5	1.2	1.2	1.2
150 VA	10.0	2.5	2.5	2.5	2.5	2.0	2.0	2.0	2.0	1.5
250 VA	12.0	4.5	4.5	4.0	4.0	3.5	3.5	3.0	3.0	3.0
300 VA	15.0	5.5	5.5	5.0	5.0	4.5	4.5	4.0	4.0	3.5
350 VA	20.0	6.5	6.0	5.5	5.5	5.0	5.0	4.5	4.5	4.5
500 VA	25.0	9.0	9.0	8.0	8.0	7.0	7.0	6.0	6.0	6.0
750 VA	40.0	12.0	12.0	12.0	12.0	10.0	10.0	10.0	10.0	9.0
1000 VA	50.0	15.0	15.0	12.0	12.0	12.0	12.0	12.0	12.0	12.0
1500 VA	—	25.0	20.0	20.0	20.0	20.0	20.0	15.0	15.0	15.0
2000 VA	—	30.0	30.0	25.0	25.0	25.0	25.0	20.0	20.0	20.0
3000 VA	—	40.0	40.0	40.0	40.0	35.0	35.0	30.0	30.0	30.0
5000 VA	—	70.0	70.0	60.0	60.0	60.0	60.0	50.0	50.0	50.0

TB SERIES SECONDARY FUSE KITS**Type PL79924, PL79930, & PL79931: Use Dual Element Slow-Blow Fuse**

Catalog Number	VA	Type
PL79924*	50-1000	1/4" x 1-1/4"
PL79930	50-350	13/32" x 1-1/2"
PL79931	500-1000	13/32" x 1-1/2"

* PL79924: Use fuse kit on all transformers except 750 & 1000 VA with 24 volt secondary.

- Mount secondary fuse clips on terminals X1 and F or F1 using the screws supplied with the transformer.
- Connect secondary load lines to terminals X2 and F or F2. Use Jumper Link to connect F1 and F2.
- Use dual-element slow-blowing fuses such as Bussmann MFG., Fusetron Type FNM, Littelfuse or Ferraz Shawmut (not supplied with fuse kits).

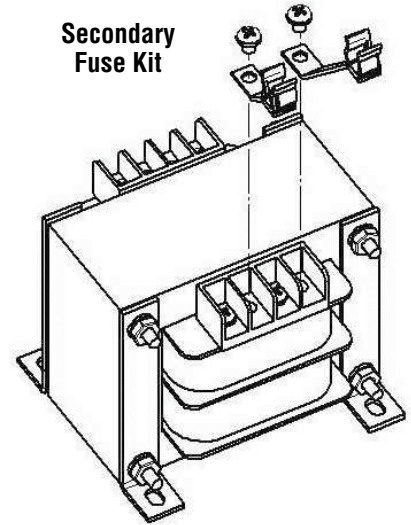
Secondary Fuse Kit**INSTRUCTIONS FOR TB SERIES SECONDARY FUSE KITS****Type PL112603: use dual element slow-blow fuse 13/32" x 1-1/2" (1.0 x 3.8 cm)**

1. To attach secondary fuse kit PL 112603 to primary fuse kits PL112700 thru PL112705 snap the secondary single pole fuse block onto the unlabeled side of the primary double pole fuse block. (See Figure 1)
2. Install the fuse kits as instructed under the primary fuse kit instructions on page 78.
3. Select the appropriate pair of jumpers for making the connections between the secondary fuse block and the secondary (X-side) of the transformer.
4. Connect the female quick-connect of the jumpers supplied to one of the male quick-connects of the secondary fuse block—one jumper to each end of the fuse block. (See Figure 2)
5. Connect the ring terminal of the jumpers supplied to screw terminals X1 and F or F1 on the secondary (X-side) of the transformer.
6. Connect secondary load lines to terminals X2 and F or F2.

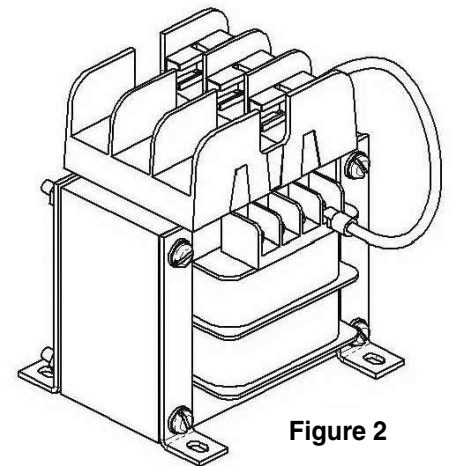
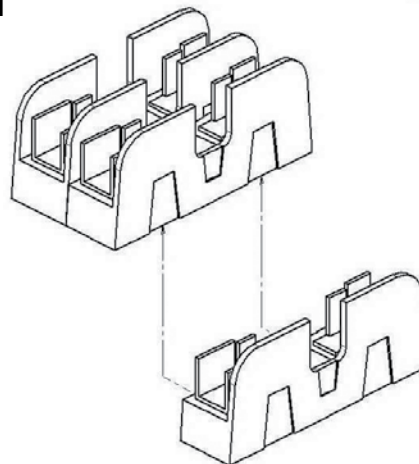
**Figure 1****Figure 2**



120 X 240 PRIMARY VOLTS — 12/24 SECONDARY VOLTS — 1Ø, 50/60 Hz

VA Rating	Catalog Number ②	Output Amps	Approximate Dimensions (Inches)(Cm.)						Approximate Ship Weight (Lbs.)(Kg.)	Primary Fuse Block Part Number	Secondary Fuse Size 24 Volts	Wiring Diagram
			A	B	C	D	E	F				
50	TB181141②	2.08	4.23	3.00	2.70	2.50	2.13	.22 x .50	4	PL112700	3 ² /10 amp	A
			(10.7)	(7.6)	(6.8)	(6.4)	(5.4)	(0.6 x 1.3)				
75	TB181142 ②	3.13	4.74	3.00	2.70	2.50	2.61	.22 x .50	4	PL112700	5 amps	A
			(12.0)	(7.6)	(6.8)	(6.4)	(6.6)	(0.6 x 1.3)				
100	TB181143 ②	4.17	4.90	3.00	2.70	2.50	2.81	.22 x .50	4	PL112700	6 ¹ / ₂ amps	A
			(12.4)	(7.6)	(6.8)	(6.4)	(7.1)	(0.6 x 1.3)				
150	TB181144 ②	6.25	4.78	3.75	3.40	3.13	2.63	.22 x .50	6	PL112701	10 amps	A
			(12.1)	(9.5)	(8.6)	(8.0)	(6.7)	(0.6 x 1.3)				
250	TB181146 ②	10.42	5.08	4.50	3.84	3.75	3.05	.22 x .50	9	PL112702	15 amps	A
			(12.9)	(11.4)	(9.8)	(9.5)	(7.7)	(0.6 x 1.3)				
350	TB181148 ②	14.58	6.12	4.50	3.84	3.75	4.06	.22 x .50	13	PL112702	20 amps	A
			(15.5)	(11.4)	(9.8)	(9.5)	(10.3)	(0.6 x 1.3)				
500	TB181149 ②	20.83	5.90	5.25	4.47	4.38	4.19	.31 x .50	16	PL112704	30 amps	A
			(15.0)	(13.3)	(11.4)	(11.1)	(10.6)	(0.8 x 1.3)				
750	TB181150	31.25	7.53	5.25	4.47	4.38	5.25	.31 x .50	24	PL112704	—	A
			(19.1)	(13.3)	(11.4)	(11.1)	(13.3)	(0.8 x 1.3)				
1000	TB181151	41.67	7.43	6.75	5.72	5.75	3.81	.31 x .50	26	PL112705	—	A
			(18.9)	(17.1)	(14.5)	(14.6)	(9.7)	(0.8 x 1.3)				

② See chart for integrally mounted fuse block catalog number suffix.

208/240/277/380/480 PRIMARY VOLTS — 24 SECONDARY VOLTS — 1Ø, 50/60 Hz

VA Rating	Catalog Number	Output Amps	Approximate Dimensions (Inches)(Cm.)						Approximate Ship Weight (Lbs.)(Kg.)	Primary Fuse Block Part Number	Secondary Fuse Kit ① Part Number	Secondary Fuse Size 24 Volts	Wiring Diagram
			A	B	C	D	E	F					
50	TB81321	2.08	4.08	3.75	3.40	3.13	2.19	.22 x .50	4	PL112701	*	3 ² /10 amp	D
			(10.4)	(9.5)	(8.6)	(8.0)	(5.6)	(0.6 x 1.3)					
75	TB81322	3.13	4.31	3.75	3.40	3.13	2.31	.22 x .50	5	PL112701	*	5 amps	D
			(10.9)	(9.5)	(8.6)	(8.0)	(5.9)	(0.6 x 1.3)					
100	TB81323	4.17	4.52	3.75	3.40	3.13	2.63	.22 x .50	5	PL112701	*	6 ¹ / ₄ amps	D
			(11.5)	(9.5)	(8.6)	(8.0)	(6.7)	(0.6 x 1.3)					
150	TB81324	6.25	4.75	4.50	3.84	3.75	3.05	.22 x .50	9	PL112702	*	10 amps	D
			(12.1)	(11.4)	(9.8)	(9.5)	(7.7)	(0.6 x 1.3)					
250	TB81325	10.42	5.24	4.65	4.15	4.06	3.25	.22 x .50	11	PL112702	*	15 amps	D
			(13.3)	(11.8)	(10.5)	(10.3)	(8.3)	(0.6 x 1.3)					
350	TB81326	14.58	6.02	5.25	4.47	4.38	4.00	.31 x .50	18	PL112704	*	20 amps	D
			(15.3)	(13.3)	(11.4)	(11.1)	(10.2)	(0.8 x 1.3)					
500	TB81327	20.83	6.51	5.25	4.47	4.38	4.19	.31 x .50	19	PL112704	*	30 amps	D
			(16.5)	(13.3)	(11.4)	(11.1)	(10.6)	(0.8 x 1.3)					
750	TB81328	31.25	7.08	6.75	5.78	5.75	3.81	.31 x .50	26	PL112705	*	—	D
			(18.0)	(17.1)	(14.7)	(14.6)	(9.7)	(0.8 x 1.3)					
1000	TB81329	41.67	8.10	6.75	5.72	5.75	4.63	.31 x .50	33	PL112705	*	—	D
			(20.6)	(17.1)	(14.5)	(14.6)	(11.8)	(0.8 x 1.3)					

① Secondary Fuse Kit PL112603 may be substituted for PL112600 thru PL112602 when Primary Fuse Kit is used. See page 79.

* See fusing chart for secondary fuse kits.



208/277/380 PRIMARY VOLTS — 115/95 SECONDARY VOLTS — 1Ø, 50/60 Hz

VA Rating	Catalog Number	Output Amps @115V	Approximate Dimensions (Inches)(Cm.)						Approximate Ship Weight (Lbs.)(Kg.)	Primary Fuse Block Part Number	Secondary Fuse Kit ① Part Number	Secondary Fuse Size 115 Volts	Wiring Diagram
			A	B	C	D	E	F					
50	TB81301	0.43	4.35	3.00	2.70	2.50	2.61	.22 x .50	4	PL112700	*	6/10 amp	E
			(11.0)	(7.6)	(6.8)	(6.4)	(6.6)	(0.6 x 1.3)					
75	TB81302	0.65	4.74	3.00	2.70	2.50	2.81	.22 x .50	4	PL112700	*	1 amp	E
			(12.0)	(7.6)	(6.8)	(6.4)	(7.1)	(0.6 x 1.3)					
100	TB81303	0.87	4.45	3.75	3.40	3.13	2.44	.22 x .50	5	PL112701	*	1 1/4 amps	E
			(11.3)	(9.5)	(8.6)	(8.0)	(6.2)	(0.6 x 1.3)					
150	TB81304	1.30	5.00	3.75	3.84	3.13	3.06	.22 x .50	5	PL112701	*	2 amps	E
			(12.7)	(9.5)	(9.8)	(8.0)	(7.8)	(0.6 x 1.3)					
250	TB81305	2.17	5.68	4.50	3.84	3.75	4.06	.22 x .50	13	PL112702	*	3 1/2 amps	E
			(14.4)	(11.4)	(9.8)	(9.5)	(10.3)	(0.6 x 1.3)					
350	TB81306	3.04	6.30	4.65	4.15	4.06	4.75	.22 x .50	18	PL112702	*	5 amps	E
			(16.0)	(11.8)	(10.5)	(10.3)	(12.1)	(0.6 x 1.3)					
500	TB81307	4.35	6.22	5.25	4.47	4.38	4.56	.22 x .50	20	PL112704	*	7 amps	E
			(15.8)	(13.3)	(11.4)	(11.1)	(11.6)	(0.6 x 1.3)					
750	TB81308	6.52	6.82	6.75	5.78	5.75	3.69	.31 x .50	24	PL112705	*	10 amps	E
			(17.3)	(17.1)	(14.7)	(14.6)	(9.4)	(0.8 x 1.3)					
1000	TB81309	8.70	7.96	6.75	5.72	5.75	4.44	.31 x .50	31	PL112705	*	12 amps	E
			(20.2)	(17.1)	(14.5)	(14.6)	(11.3)	(0.8 x 1.3)					

① Secondary Fuse Kit PL112603 may be substituted for PL112600 thru PL112602 when Primary Fuse Kit is used. See page 79.

* See fusing chart for secondary fuse kits.

208/230/460 PRIMARY VOLTS — 115 SECONDARY VOLTS — 1Ø, 50/60 Hz

VA Rating	Catalog Number	Output Amps	Approximate Dimensions (Inches)(Cm.)						Approximate Ship Weight (Lbs.)(Kg.)	Primary Fuse Block Part Number	Secondary Fuse Kit ① Part Number	Secondary Fuse Size 115 Volts	Wiring Diagram
			A	B	C	D	E	F					
50	TB69300	0.43	4.44	3.00	2.70	2.50	2.61	.22 x .50	4	PL112700	*	6/10 amp	H
			(11.3)	(7.6)	(6.8)	(6.4)	(6.6)	(0.6 x 1.3)					
100	TB69301	0.87	5.21	3.00	2.70	2.50	3.26	.22 x .50	4	PL112700	*	1 4/10 amps	H
			(13.2)	(7.6)	(6.8)	(6.4)	(8.3)	(0.6 x 1.3)					
150	TB69302	1.30	5.10	3.75	3.40	3.13	3.06	.22 x .50	7	PL112701	*	2 amps	H
			(13.0)	(9.5)	(8.6)	(8.0)	(7.8)	(0.6 x 1.3)					
250	TB69303	2.17	5.38	4.50	3.84	3.75	3.50	.22 x .50	11	PL112702	*	3 1/2 amps	H
			(13.7)	(11.4)	(9.8)	(9.5)	(8.9)	(0.6 x 1.3)					
350	TB69304	3.04	5.90	4.65	4.15	4.06	3.81	.22 x .50	15	PL112702	*	5 amps	H
			(15.0)	(11.8)	(10.5)	(10.3)	(9.7)	(0.6 x 1.3)					
500	TB69305	4.35	6.22	5.25	4.47	4.38	4.56	.31 x .50	20	PL112704	*	7 amps	H
			(15.8)	(13.3)	(11.4)	(11.1)	(11.6)	(0.8 x 1.3)					
750	TB69306	6.52	6.82	6.75	5.78	5.75	3.81	.31 x .50	26	PL112705	*	10 amps	H
			(17.3)	(17.1)	(14.7)	(14.6)	(9.7)	(0.8 x 1.3)					
1000	TB69307	8.70	7.96	6.75	5.78	5.75	4.63	.31 x .50	33	PL112705	*	12 amps	H
			(20.2)	(17.1)	(14.7)	(14.6)	(11.8)	(0.8 x 1.3)					

* See fusing chart for secondary fuse kits.

① Secondary Fuse Kit PL112603 may be substituted for PL112600 thru PL112602 when Primary Fuse Kit is used. See page 79.



208/277 PRIMARY — 12 SECONDARY VOLTS — 50/60 Hz

VA Rating	Catalog Number	Output Amps @12V	Approximate Dimensions (Inches)(Cm.)						Approximate Ship Weight (Lbs.)(Kg.)	Wiring Diagram
			A	B	C	D	E	F		
50	TB080050	4.16	4.23	3.00	2.70	2.50	2.13	.22 x .50	4	L
			(10.74)	(7.62)	(6.85)	(6.35)	(5.41)	(0.6 x 1.3)	(1.8)	
75	TB080075	6.25	4.74	3.00	2.70	2.50	2.61	.22 x .50	4	L
			(12.03)	(7.62)	(6.85)	(6.35)	(6.62)	(0.6 x 1.3)	(1.8)	
100	TB080100	8.33	4.90	3.00	2.70	2.50	2.81	.22 x .50	4	L
			(12.44)	(7.62)	(6.85)	(6.35)	(7.13)	(0.6 x 1.3)	(1.8)	
150	TB080150	12.50	4.78	3.75	3.40	3.13	2.63	.22 x .50	6	L
			(12.14)	(9.52)	(8.63)	(7.95)	(6.68)	(0.6 x 1.3)	(2.7)	
250	TB080250	20.83	5.08	4.50	3.84	3.75	3.05	.22 x .50	9	L
			(12.90)	(11.43)	(9.75)	(9.52)	(0)	(0.6 x 1.3)	(4.1)	
350	TB080350	29.16	6.12	4.50	3.84	3.75	4.06	.22 x .50	13	L
			(15.54)	(11.43)	(9.75)	(9.52)	(10.31)	(0.6 x 1.3)	(5.9)	
500	TB080500	41.66	5.90	5.25	4.47	4.38	4.19	.31 x .50	16	L
			(14.98)	(13.33)	(11.35)	(11.12)	(10.64)	(0.8 x 1.3)	(7.25)	
750	TB080750	62.50	7.53	5.25	4.47	4.38	5.25	.31 x .50	24	L
			(19.12)	(13.33)	(11.35)	(11.12)	(13.33)	(0.8 x 1.3)	(10.88)	
1000	TB081000	83.33	7.43	6.75	5.72	5.75	3.81	.31 x .50	26	L
			(18.87)	(17.14)	(14.52)	(4.60)	(9.67)	(0.8 x 1.3)	(11.79)	

240 X 480, 230 X 460, 220 X 440 PRIMARY VOLTS — 120/115/110 SECONDARY VOLTS — 1Ø, 50/60 Hz

VA Rating	Catalog Number ②	Output Amps @120V	Approximate Dimensions (Inches)(Cm.)						Approximate Ship Weight (Lbs.)(Kg.)	Primary Fuse Block Part Number	Secondary Fuse Kit ① Part Number	Secondary Fuse Size 120 Volts	Wiring Diagram
			A	B	C	D	E	F					
50	TB81210 ②	0.42	4.23	3.00	2.70	2.50	2.13	.22 x .50	4	PL112700	*	6/10 amp	B
			(10.7)	(7.6)	(6.8)	(6.4)	(5.4)	(0.6 x 1.3)	(1.8)				
75	TB81201 ②	0.63	4.74	3.00	2.70	2.50	2.61	.22 x .50	4	PL112700	*	1 amp	B
			(12.0)	(7.6)	(6.8)	(6.4)	(6.6)	(0.6 x 1.3)	(1.8)				
100	TB81211 ②	0.83	4.90	3.00	2.70	2.50	2.81	.22 x .50	4	PL112700	*	1 1/4 amps	B
			(12.4)	(7.6)	(6.8)	(6.4)	(7.1)	(0.6 x 1.3)	(1.8)				
150	TB81212 ②	1.25	5.00	3.75	3.40	3.13	2.81	.22 x .50	6	PL112701	*	2 amps	B
			(12.7)	(9.5)	(8.6)	(8.0)	(7.1)	(0.6 x 1.3)	(2.7)				
250	TB81213 ②	2.08	4.18	4.50	3.84	3.75	3.13	.22 x .50	9	PL112702	*	3 2/10 amps	B
			(10.6)	(11.4)	(9.8)	(9.5)	(8.0)	(0.6 x 1.3)	(4.1)				
300	TB81200 ②	2.50	5.57	4.50	3.84	3.75	3.13	.22 x .50	10	PL112702	*	4 amps	B
			(14.1)	(11.4)	(9.8)	(9.5)	(8.0)	(0.6 x 1.3)	(4.5)				
350	TB81214 ②	2.92	6.32	4.50	3.84	3.75	3.83	.22 x .50	12	PL112702	*	4 1/2 amps	B
			(16.1)	(11.4)	(9.8)	(9.5)	(9.7)	(0.6 x 1.3)	(5.4)				
500	TB81215 ②	4.17	6.30	5.25	4.47	4.06	3.81	.22 x .50	15	PL112704	*	6 1/4 amps	B
			(16.0)	(13.3)	(11.4)	(10.3)	(9.7)	(0.6 x 1.3)	(6.8)				
750	TB81216 ②	6.25	6.65	5.25	4.47	4.38	5.13	.31 x .50	23	PL112704	*	10 amps	B
			(16.9)	(13.3)	(11.4)	(11.1)	(13.0)	(0.8 x 1.3)	(10.4)				
1000	TB81217 ②	8.33	7.58	6.75	5.78	5.75	3.69	.31 x .50	25	PL112705	*	12 amps	B
			(19.3)	(17.1)	(14.7)	(14.6)	(9.4)	(0.8 x 1.3)	(11.3)				

① Secondary Fuse Kit PL112603 may be substituted for PL112600 thru PL112602 when Primary Fuse Kit is used. See page 79.

② See chart for integrally mounted fuse block catalog number suffix.



240 X 480, 230 X 460, 220 X 440 PRIMARY VOLTS — 120/115/110 SECONDARY VOLTS — 1Ø, 50/60 Hz (Cont.)

VA Rating	Catalog Number ^②	Output Amps @120V	Approximate Dimensions (Inches)(Cm.)						Approximate Ship Weight (Lbs.)(Kg.)	Primary Fuse Block Part Number	Secondary Fuse Kit ^① Part Number	Secondary Fuse Size 120 Volts	Wiring Diagram
			A	B	C	D	E	F					
1500	TA281218	12.50	8.80	6.75	5.72	5.75	5.75	.31 x .50	43	PL112705	PL112601	15 amps	B
			(22.4)	(17.1)	(14.5)	(14.6)	(14.6)	(0.8 x 1.3)					
2000	TA281219	16.67	9.25	6.75	5.72	5.75	6.38	.31 x .50	49	PL112705	PL112601	20 amps	B
			(23.5)	(17.1)	(14.5)	(14.6)	(16.2)	(0.8 x 1.3)					
3000	TA281220	25.00	8.81	7.50	8.34	6.50	7.52	.41 x .81	70	PL112706	—	—	B
			(22.4)	(19.1)	(21.2)	(16.5)	(19.1)	(1.0 x 2.1)					
5000	TA281221	41.67	7.52	11.92	9.49	6.75	6.25	.41 x .81	125	PL112707	—	—	B
			(12.7)	(9.5)	(8.6)	(8.0)	(7.1)	(0.6 x 1.3)					

① Secondary Fuse Kit PL112603 may be substituted for PL112600 thru PL112602 when Primary Fuse Kit is used. See page 76.

② See chart for integrally mounted fuse block catalog number suffix.

240/480/600, 230/460/575, 220/440/550 PRIMARY VOLTS — 120/100, 115/95, 110/90 SECONDARY VOLTS — 1Ø, 50/60 Hz

VA Rating	Catalog Number ^②	Output Amps @120V	Approximate Dimensions (Inches)(Cm.)						Approximate Ship Weight (Lbs.)(Kg.)	Primary Fuse Block Part Number	Secondary Fuse Kit ^① Part Number	Secondary Fuse Size 120 Volts	Wiring Diagram
			A	B	C	D	E	F					
50	TB81000	0.42	4.56	3.00	2.70	2.50	2.61	.22 x .50	4	PL112700	*	6/10 amp	C
			(11.6)	(7.6)	(6.8)	(6.4)	(6.6)	(0.6 x 1.3)					
75	TB81009	0.63	4.90	3.00	2.70	2.50	2.81	.22 x .50	4	PL112700	*	1 amp	C
			(12.4)	(7.6)	(6.8)	(6.4)	(7.1)	(0.6 x 1.3)					
100	TB81001	0.83	5.36	3.00	2.70	2.50	3.26	.22 x .50	5	PL112700	*	1 ¹ / ₄ amps	C
			(13.6)	(7.6)	(6.8)	(6.4)	(8.3)	(0.6 x 1.3)					
150	TB81002	1.25	5.00	3.75	3.40	3.13	3.06	.22 x .50	7	PL112701	*	2 amps	C
			(12.7)	(9.5)	(8.6)	(8.0)	(7.8)	(0.6 x 1.3)					
250	TB81003	2.08	5.57	4.50	3.84	3.75	3.50	.22 x .50	11	PL112702	*	3 ² / ₁₀ amps	C
			(14.1)	(11.4)	(9.8)	(9.5)	(8.9)	(0.6 x 1.3)					
300	TB81020	2.50	6.48	4.65	4.15	4.06	4.06	.22 x .50	15	PL112702	*	4 amps	C
			(16.5)	(11.8)	(10.5)	(10.3)	(10.3)	(0.6 x 1.3)					
350	TB81004	2.92	6.48	4.65	4.15	4.06	4.06	.22 x .50	15	PL112702	*	4 ¹ / ₂ amps	C
			(16.5)	(11.8)	(10.5)	(10.3)	(10.3)	(0.6 x 1.3)					
500	TB81005	4.17	6.43	5.25	4.47	4.38	4.56	.31 x .50	21	PL112704	*	6 ¹ / ₄ amps	C
			(16.3)	(13.3)	(11.4)	(11.1)	(11.6)	(0.8 x 1.3)					
750	TB81006	6.25	7.19	6.75	5.78	5.75	3.81	.31 x .50	25	PL112705	*	10 amps	C
			(18.3)	(17.1)	(14.7)	(14.6)	(9.7)	(0.8 x 1.3)					
1000	TB81007	8.33	7.96	6.75	5.78	5.75	4.63	.31 x .50	32	PL112705	*	12 amps	C
			(20.2)	(17.1)	(14.7)	(14.6)	(11.8)	(0.8 x 1.3)					
1500	TA281008	12.50	9.46	6.75	5.72	5.75	6.38	.31 x .50	47	PL112705	PL112601	15 amps	C
			(24.0)	(17.1)	(14.5)	(14.6)	(16.2)	(0.8 x 1.3)					
2000	TA253929	16.67	7.90	7.50	7.66	6.50	6.57	.41 x .81	55	PL112706	PL112601	20 amps	C
			(20.1)	(19.1)	(19.5)	(16.5)	(16.7)	(1.0 x 2.1)					
3000	TA253930	25.00	7.02	11.92	8.83	6.75	5.75	.41 x .81	75	PL112707	—	—	C
			(17.8)	(30.3)	(22.4)	(17.1)	(14.6)	(1.0 x 2.1)					
5000	TA253931	41.67	7.52	11.92	9.49	6.75	6.25	.41 x .81	110	PL112707	—	—	C
			(19.1)	(30.3)	(24.1)	(17.1)	(15.9)	(1.0 x 2.1)					

① Secondary Fuse Kit PL112603 may be substituted for PL112600 thru PL112602 when Primary Fuse Kit is used. See page 79 for "TB" units and page 76 for "TA" units.

* See fusing chart for secondary fuse kits.

② See chart for integrally mounted fuse block catalog number suffix



**240/416/480/600; 230/400/460/575; 220/380/440/550; 208/500 PRIMARY VOLTS
99/120/130; 95/115/125; 91/110/120; 85/100/110 SECONDARY VOLTS — 1Ø, 50/60 Hz**

VA Rating @ 130V	Catalog Number	Output Amps	Approximate Dimensions (Inches)(Cm.)						Approximate Ship Weight (Lbs.)(Kg.)	Primary Fuse Block Part Number	Secondary Fuse Kit Part Number	Secondary Fuse Size 130 Volts	Wiring Diagram
			A	B	C	D	E	F					
50	TB32403	0.38	4.08 (10.4)	3.75 (9.5)	3.40 (8.6)	3.13 (8.0)	2.31 (5.9)	.22 x .50 (0.6 x 1.3)	5 (2.3)	PL112701	NA	6 ¹ / ₁₀ amp	G
150	TB32404	1.15	4.75 (12.1)	4.50 (11.4)	3.84 (9.8)	3.75 (9.5)	3.05 (7.7)	.22 x .50 (0.6 x 1.3)	10 (4.5)	PL112702	NA	1 ⁶ / ₁₀ amps	G
250	TB32405	1.92	5.58 (14.2)	4.65 (11.8)	4.15 (10.5)	4.06 (10.3)	4.06 (10.3)	.22 x .50 (0.6 x 1.3)	16 (7.3)	PL112702	NA	3 ² / ₁₀ amps	G
350	TB32669	2.69	6.23 (15.8)	4.65 (11.8)	4.15 (10.5)	4.06 (10.3)	5.50 (14.0)	.22 x .50 (0.6 x 1.3)	22 (10.0)	PL112702	NA	4 amps	G
500	TB32406	3.85	6.40 (16.3)	6.75 (17.1)	5.78 (14.7)	5.75 (14.6)	3.69 (9.4)	.22 x .50 (0.6 x 1.3)	23 (10.4)	PL112705	NA	6 ¹ / ₄ amps	G
750	TB54523	5.77	7.08 (18.0)	6.75 (17.1)	5.78 (14.7)	5.75 (14.6)	4.13 (10.5)	.31 x .50 (0.8 x 1.3)	29 (13.2)	PL112705	NA	9 amps	G
1000	TB54524	7.69	8.56 (21.7)	6.75 (17.1)	5.78 (14.7)	5.75 (14.6)	4.88 (12.4)	.31 x .50 (0.8 x 1.3)	35 (15.9)	PL112705	NA	12 amps	G
1500	TA254525	11.54	6.75 (17.1)	7.50 (19.1)	7.66 (19.5)	6.50 (16.5)	5.42 (13.8)	.41 x .81 (1.0 x 2.1)	55 (24.9)	PL112706	PL-112601	20 amps	G
2000	TA281202	15.39	7.45 (18.9)	7.50 (19.1)	7.66 (19.5)	6.50 (16.5)	6.12 (15.5)	.41 x .81 (1.0 x 2.1)	55 (24.9)	PL112706	PL-112601	25 amps	G
3000	TA281203	23.08	7.02 (17.8)	11.92 (30.3)	8.83 (22.4)	6.75 (17.1)	5.75 (14.6)	.41 x .81 (1.0 x 2.1)	70 (31.8)	PL112707	—	—	G
5000	TA281205	38.46	7.52 (19.1)	11.92 (30.3)	9.49 (24.1)	6.75 (17.1)	6.25 (15.9)	.41 x .81 (1.0 x 2.1)	110 (49.9)	PL112707	—	—	G

CONNECTION DETAILS FOR WIRING DIAGRAM G

Output Volts						
H1-H2	H1-H3	H1-H4	H1-H5	X1-X2	X1-X3	X1-X4
208	—	—	500	85	100	110
220	380	440	550	91	110	120
230	400	460	575	95	115	125
240	416	480	600	99	120	130



240 X 480 PRIMARY VOLTS — 120/240 SECONDARY VOLTS — 1Ø, 60 Hz

VA Rating	Catalog Number	Output Amps @120V	Approximate Dimensions (Inches)(Cm.)						Approximate Ship Weight (Lbs.)(Kg.)	Primary Fuse Block Part Number	Wiring Diagram
			A	B	C	D	E	F			
50	TB83210	0.42	4.13	3.00	2.70	2.50	2.30	.22 x .50	4	PL112700	J
			(10.5)	(7.6)	(6.8)	(6.4)	(5.8)	(0.6 x 1.3)			
100	TB83212	0.83	4.90	3.00	2.70	2.50	3.35	.22 x .50	4	PL112700	J
			(12.4)	(7.6)	(6.8)	(6.4)	(8.5)	(0.6 x 1.3)			
150	TB83213	1.25	4.92	3.75	3.40	3.13	2.81	.22 x .50	6	PL112701	J
			(12.5)	(9.5)	(8.6)	(8.0)	(7.1)	(0.6 x 1.3)			
250	TB83215	2.08	5.38	4.50	3.84	3.75	3.05	.22 x .50	9	PL112702	J
			(13.7)	(11.4)	(9.8)	(9.5)	(7.7)	(0.6 x 1.3)			
500	TB83218	4.17	6.06	5.25	4.47	4.06	4.06	.22 x .50	13	PL112704	J
			(15.4)	(13.3)	(11.4)	(10.3)	(10.3)	(0.6 x 1.3)			
750	TB83219	6.25	6.43	5.25	4.47	4.38	5.30	.31 x .50	21	PL112704	J
			(16.3)	(13.3)	(11.4)	(11.1)	(13.0)	(0.8 x 1.3)			
1000	TB83220	8.33	7.34	6.75	5.78	5.75	3.69	.31 x .50	24	PL112705	J
			(18.6)	(17.1)	(14.7)	(14.6)	(9.4)	(0.8 x 1.3)			
1500	TA83221	12.50	8.80	6.75	5.72	5.75	5.02	.31 x .50	43	PL112705	J
			(22.4)	(17.1)	(14.5)	(14.6)	(12.8)	(0.8 x 1.3)			
2000	TA83222	16.67	9.15	6.75	5.72	5.75	5.42	.31 x .50	48	PL112705	J
			(23.2)	(17.1)	(14.5)	(14.6)	(13.8)	(0.8 x 1.3)			
3000	TA83223	25.00	7.00	7.50	7.66	6.50	5.55	.41 x .81	51	PL112706	J
			(17.8)	(19.1)	(19.5)	(16.5)	(14.1)	(1.0 x 2.1)			
5000	TA83224	41.67	7.06	11.92	8.75	6.75	5.75	.41 x .81	90	PL112707	J
			(17.9)	(30.3)	(22.2)	(17.1)	(14.6)	(1.0 x 2.1)			

INTEGRALLY MOUNTED FUSE BLOCKS
120X240-12/24: 50-500VA (F2 Option Only)
240X480-120/115/110: 50-2000VA

Add Suffix to Catalog Number	Configuration
F2	Factory installed integrally mounted 2-pole primary block
F3	Factory installed integrally mounted 3-pole primary and secondary block (100 VA & larger)
F4	Factory installed 2-pole primary block and secondary fuse clips (50 & 75 VA)

Consult factory for other sizes available.



380/440/550/600 PRIMARY VOLTS — 115/230 SECONDARY VOLTS — 1Ø, 50/60 Hz

VA Rating	Catalog Number	Output Amps @115V	Approximate Dimensions (Inches)(Cm.)						Approximate Ship Weight (Lbs.)(Kg.)	Primary Fuse Block Part Number	Secondary Fuse Size 115 Volts	Wiring Diagram
			A	B	C	D	E	F				
50	TA254535	0.43	4.12 (10.5)	3.75 (9.5)	3.21 (8.2)	3.13 (8.0)	2.19 (5.6)	.22 x .50 (0.6 x 1.3)	4 (1.8)	PL112701	6 ¹ / ₁₀ amp	F
100	TA254536	0.87	4.56 (11.6)	3.75 (9.5)	3.21 (8.2)	3.13 (8.0)	2.31 (5.9)	.22 x .50 (0.6 x 1.3)	5 (2.3)	PL112701	1 ¹ / ₄ amps	F
150	TA254537	1.30	5.00 (12.7)	3.75 (9.5)	3.21 (8.2)	3.13 (8.0)	3.06 (7.8)	.22 x .50 (0.6 x 1.3)	10 (4.5)	PL112701	2 amps	F
250	TA254538	2.17	5.49 (13.9)	4.50 (11.4)	3.84 (9.8)	3.75 (9.5)	3.50 (8.9)	.22 x .50 (0.6 x 1.3)	11 (5.0)	PL112702	3 ¹ / ₂ amps	F
350	TA281197	3.04	6.03 (15.3)	4.88 (12.4)	4.15 (10.5)	4.06 (10.3)	4.38 (11.1)	.22 x .50 (0.6 x 1.3)	17 (7.7)	PL112703	5 amps	F
500	TA254539	4.35	6.76 (17.1)	4.88 (12.4)	4.15 (10.5)	4.06 (10.3)	5.75 (14.6)	.22 x .50 (0.6 x 1.3)	23 (10.4)	PL112703	7 amps	F
750	TA281240	6.52	7.19 (18.3)	6.75 (17.1)	5.72 (14.5)	5.75 (14.6)	3.69 (9.4)	.31 x .50 (0.8 x 1.3)	25 (11.3)	PL112705	10 amps	F
1000	TA281241	8.70	7.77 (19.7)	6.75 (17.1)	5.72 (14.5)	5.75 (14.6)	4.44 (11.3)	.31 x .50 (0.8 x 1.3)	30 (13.6)	PL112705	12 amps	F

600 PRIMARY VOLTS — 12/24 SECONDARY VOLTS — 1Ø, 60 Hz

VA Rating	Catalog Number	Output Amps @12V	Approximate Dimensions (Inches)(Cm.)						Approximate Ship Weight (Lbs.)(Kg.)	Primary Fuse Block Part Number	Wiring Diagram
			A	B	C	D	E	F			
50	TA83300	4.17	4.13 (10.5)	3.00 (7.6)	2.59 (6.6)	2.50 (6.4)	2.30 (5.8)	.22 x .50 (0.6 x 1.3)	4 (1.8)	PL112700	I
100	TA83301	8.33	4.90 (12.4)	3.00 (7.6)	2.59 (6.6)	2.50 (6.4)	3.35 (8.5)	.22 x .50 (0.6 x 1.3)	4 (1.8)	PL112700	I
150	TA83302	12.50	4.92 (12.5)	3.75 (9.5)	3.21 (8.2)	3.13 (8.0)	2.81 (7.1)	.22 x .50 (0.6 x 1.3)	6 (2.7)	PL112701	I
250	TA83303	20.83	5.38 (13.7)	4.50 (11.4)	3.84 (9.8)	3.75 (9.5)	3.05 (7.7)	.22 x .50 (0.6 x 1.3)	9 (4.1)	PL112702	I
500	TA83304	41.67	6.06 (15.4)	4.88 (12.4)	4.15 (10.5)	4.06 (10.3)	4.06 (10.3)	.22 x .50 (0.6 x 1.3)	13 (5.9)	PL112703	I
750	TA83305	62.50	6.43 (16.3)	5.25 (13.3)	4.47 (11.4)	4.38 (11.1)	4.00 (10.2)	.31 x .50 (0.8 x 1.3)	21 (9.5)	PL112704	I
1000	TA83306	83.33	7.30 (18.5)	6.75 (17.1)	5.72 (14.5)	5.75 (14.6)	3.69 (9.4)	.31 x .50 (0.8 x 1.3)	24 (10.9)	PL112705	I



600 PRIMARY VOLTS — 120/240 SECONDARY VOLTS — 1Ø, 60 Hz

VA Rating	Catalog Number	Output Amps @120V	Approximate Dimensions (Inches)(Cm.)						Approximate Ship Weight (Lbs.)(Kg.)	Primary Fuse Block Part Number	Wiring Diagram
			A	B	C	D	E	F			
50	TA83310	0.42	4.13	3.00	2.59	2.50	2.30	.22 x .50	4	PL112700	K
			(10.5)	(7.6)	(6.6)	(6.4)	(5.8)	(0.6 x 1.3)			
100	TA83311	0.83	4.90	3.00	2.59	2.50	3.35	.22 x .50	4	PL112700	K
			(12.4)	(7.6)	(6.6)	(6.4)	(8.5)	(0.6 x 1.3)			
150	TA83312	1.25	4.92	3.75	3.21	3.13	2.81	.22 x .50	6	PL112701	K
			(12.5)	(9.5)	(8.2)	(8.0)	(7.1)	(0.6 x 1.3)			
250	TA83313	2.08	5.38	4.50	3.84	3.75	3.05	.22 x .50	9	PL112702	K
			(13.7)	(11.4)	(9.8)	(9.5)	(7.7)	(0.6 x 1.3)			
500	TA83314	4.17	6.06	4.88	4.15	4.06	4.06	.22 x .50	13	PL112703	K
			(15.4)	(12.4)	(10.5)	(10.3)	(10.3)	(0.6 x 1.3)			
750	TA83315	6.25	6.43	5.25	4.47	4.38	4.00	.31 x .50	21	PL112704	K
			(16.3)	(13.3)	(11.4)	(11.1)	(10.2)	(0.8 x 1.3)			
1000	TA83316	8.33	7.34	6.75	5.72	5.75	3.69	.31 x .50	24	PL112705	K
			(18.6)	(17.1)	(14.5)	(14.6)	(9.4)	(0.8 x 1.3)			

TA & TB SERIES PROTECTIVE DEVICES — Primary Fuse Kits
 FUSES ARE NOT INCLUDED. CONSULT CATALOG FOR PROPER FUSE SELECTION

Catalog Number	Approximate Ship Weight (Lbs.)(Kg.)
PL112700	1 (0.5)
PL112701	1 (0.5)
PL112702	1 (0.5)
PL112703	1 (0.5)
PL112704	1 (0.5)
PL112705	1 (0.5)
PL112706	1 (0.5)
PL112707	1 (0.5)

TA SERIES PROTECTIVE DEVICES — Secondary Fuse Kits
 FOR USE WITH INDUSTRIAL CONTROL TRANSFORMERS THROUGH 1500 VA

Catalog Number	Approximate Ship Weight (Lbs.)(Kg.)
PL112600	0.5 (0.2)
PL112601	0.5 (0.2)
PL112602	1 (0.5)
PL112603	1 (0.5)

TB SERIES PROTECTIVE DEVICES — Secondary Fuse Kits

Catalog Number	VA	Description	Approximate Ship Weight (Lbs.)(Kg.)
PL79924		Fuse Kit: Secondary Fuse 1/4" x 1-1/4" w/ARM	1.0 (0.5)
PL79928	50–350	Link: Small Jumper Links (Qty. 2)	1.0 (0.5)
PL79929	500 & 750	Link: Large Jumper Links (Qty. 2)	1.0 (0.5)
PL79930	50–350	Fuse Kit: Secondary Fuse Midget w/ARM	1.0 (0.5)
PL79931	500 & 1000	Fuse Kit: Secondary Fuse Midget w/ARM	1.0 (0.5)



TA SERIES OPEN CORE AND COIL WIRING DIAGRAMS

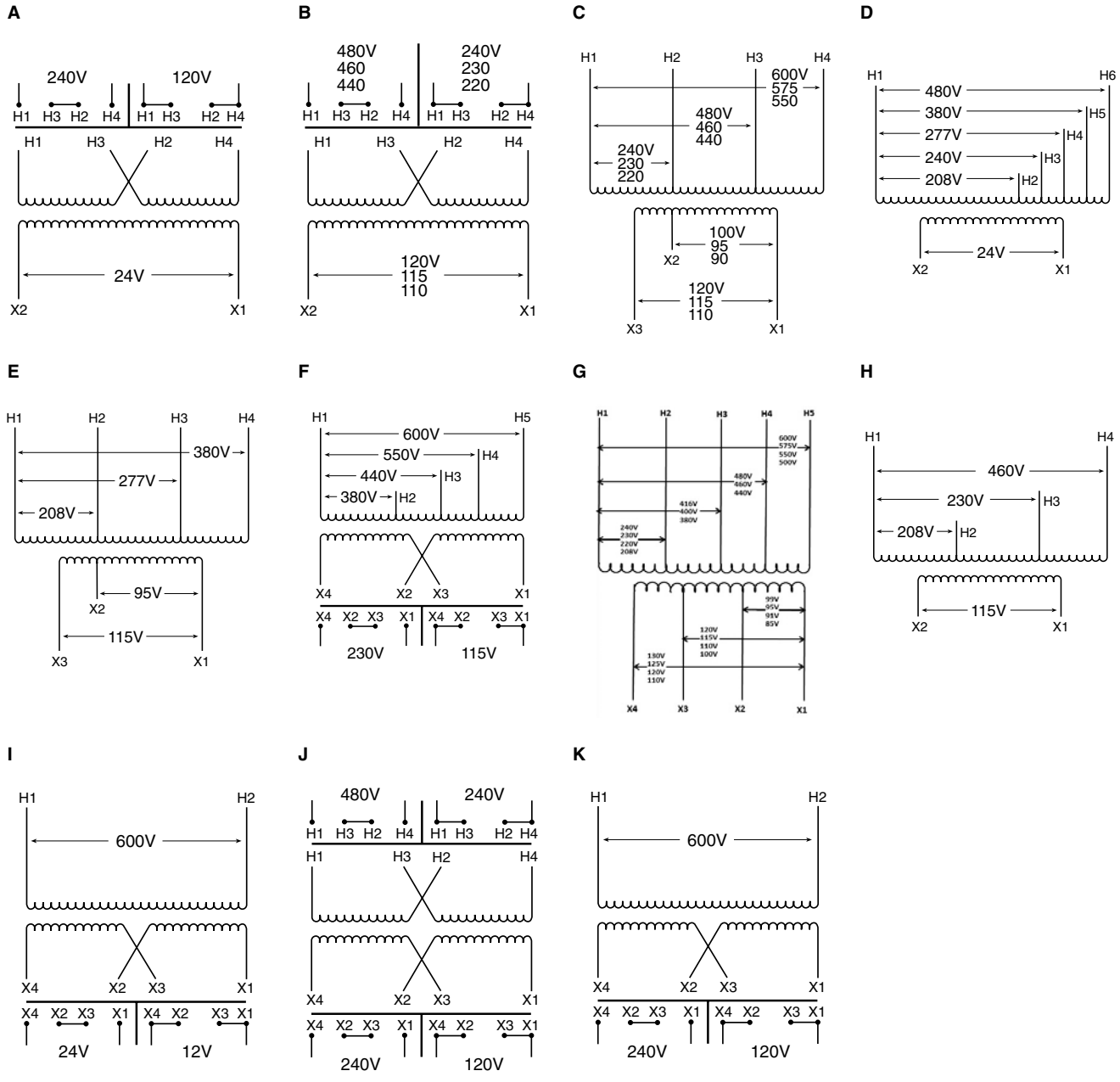

TA SERIES OPEN CORE AND COIL DIMENSIONAL DRAWINGS

50 VA THRU 2 kVA

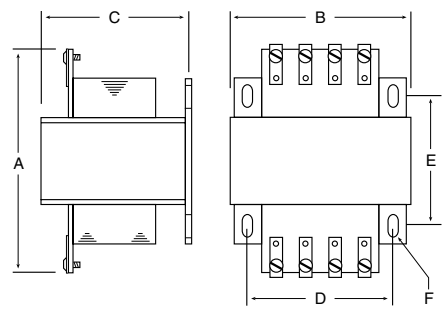

3 AND 5 kVA

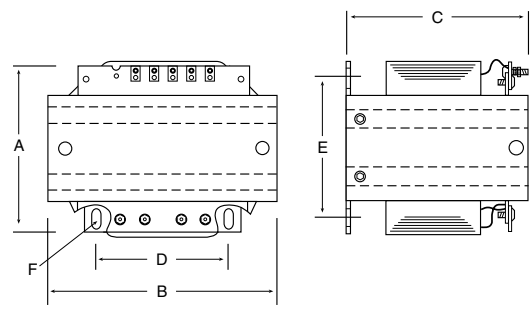



TB SERIES OPEN CORE AND COIL WIRING DIAGRAMS

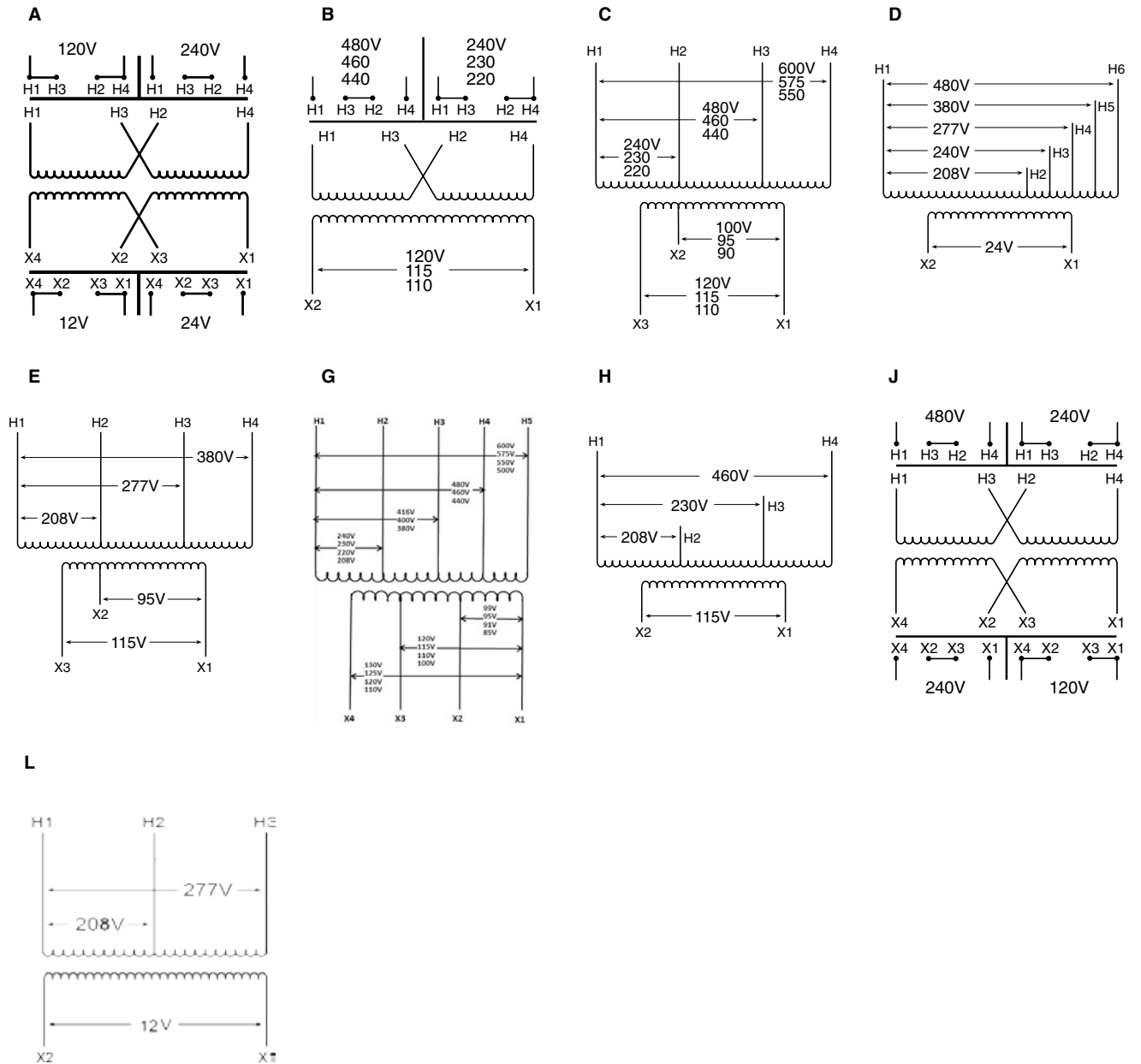

TB SERIES OPEN CORE AND COIL DIMENSIONAL DRAWINGS

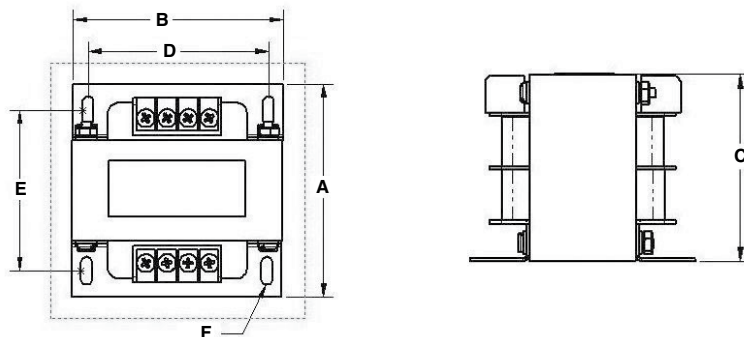

INDUSTRIAL CONTROL TRANSFORMERS FOR HARSH ENVIRONMENTS

Designed for control panels where internal installation of Control Transformers is prohibited

Some specifications require installation of large control transformers, usually 1000 to 5000 VA outside the control cabinet. This means the transformer must be in a sheet metal enclosure instead of the usual open core and coil construction method.

Acme meets this need by providing all of the power, protection, regulation and performance of our standard industrial control transformers in one UL-3R enclosure. These transformers are wound with copper magnet wire, deliver full nameplate capacity, and provide the high regulation required in control applications.

Voltage combinations available are: 240 x 480V primary, 120V secondary and 240/480/600V primary, 120/100V secondary. Ratings available are 1000, 2000, 3000 and 5000 VA. All units are UL listed, CSA certified, and covered by Acme's exclusive 10-year limited warranty.

Features

- Fully encapsulated and enclosed
- 55°C temperature rise, 155°C insulation
- Copper windings
- 1000, 2000, 3000, 5000 and 10000 VA sizes
- Voltage regulation exceeds NEMA requirements
- UL and UL-3R listed
- CSA certified
- 10-year limited warranty



240 X 480 PRIMARY VOLTS — 120 SECONDARY VOLTS — 1Ø, 50/60 Hz

VA Rating	Catalog Number	Output Amps	Height (Inches)(Cm.)	Width (Inches)(Cm.)	Depth (Inches)(Cm.)	Weight (Lbs.)(Kg.)	Wiring Diagram ① ②
1000	T181217	8.33	13.10 (33.3)	10.31 (26.2)	7.13 (18.1)	55 (24.9)	B
2000	T181219	16.67	14.77 (37.5)	10.31 (26.2)	7.13 (18.1)	80 (36.3)	B
3000	T181220	25.00	14.77 (37.5)	10.31 (26.2)	7.13 (18.1)	100 (45.4)	B
5000	T181221	41.67	13.85 (35.2)	13.25 (33.7)	10.19 (25.9)	140 (63.5)	B
10000	T181223	83.3	16.47 (41.8)	13.88 (35.3)	12.94 (32.9)	308 (139.7)	B

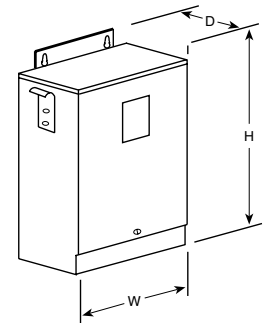

**Encapsulated
1000 VA–10000 VA**

① See page 88 for electrical diagram.
 ② See page 78 for fuse sizing information.
 For secondary fuse size, multiply output amps x 1.25.

240/480/600 PRIMARY VOLTS — 120/100 SECONDARY VOLTS — 1Ø, 50/60 Hz

VA Rating	Catalog Number	Output Amps	Height (Inches)(Cm.)	Width (Inches)(Cm.)	Depth (Inches)(Cm.)	Weight (Lbs.)(Kg.)	Wiring Diagram ① ②
2000	T153929	16.67	14.77 (37.5)	10.31 (26.2)	7.13 (18.1)	80 (36.3)	C
3000	T153930	25.00	13.85 (35.2)	13.25 (33.7)	10.19 (25.9)	130 (59.0)	C
5000	T153931	41.67	13.85 (35.2)	13.25 (33.7)	10.19 (25.9)	140 (63.5)	C

① See page 88 for electrical diagram.
 ② See page 78 for fuse sizing information.
 ③ For secondary fuse size, multiply output amps x 1.25.

AE/CE SERIES INDUSTRIAL CONTROL TRANSFORMERS

The Acme Electric AE and CE Series Industrial Control Transformers are designed specifically for machine tool control circuit applications. These transformers have the ability to handle potentially damaging high in-rush currents that occur when electromagnetic components are energized, without sacrificing the required stable output voltage. Designed to meet or exceed the demands of international standards, combined with the full breadth of product offering, the AE and CE Series Transformers from Acme Electric are the ideal solution for your industrial control applications.

Cooler. Cleaner. More Compact.

The AE and CE Series design improves the dissipation of the heat away from the core and coil assembly providing cooler operation. In addition, the AE and CE Series industrial control transformers seal the transformer's windings and internal terminations within an epoxy encapsulant encased in a durable thermoplastic end cap, protecting them from potentially damaging moisture, dirt and other ambient contaminants. Furthermore, Acme's compact design helps minimize the mounting footprint, providing more flexibility in applications where space is at a premium.

Features

- Epoxy encapsulated design protects core & coil assembly from potentially damaging contaminants
- Integrally molded terminal blocks with isolation barriers to prevent arc over, terminal blocks allow full access for ring terminals for easy installation and solid termination
- Heavy gauge steel mounting feet
- Available factory or field installed fuse blocks provide integral fusing on the primary or primary and secondary
- Dual labeling for easy product identification when equipped with a fuse block
- 50-750 VA, 50/60 Hz
- UL and cUL Listed, CE Marked (CE Series only)
- Ten-year limited warranty
- 55°C Temperature Rise
- 105°C Insulation Class

CE Series for Global Applications

Acme's CE Series Encapsulated Industrial Control Transformers carry the CE mark, indicating it complies with the requirements established by the International Electrotechnical Commission (IEC) for use of control circuit transformers in the countries of the European Union. Regulations that apply to control transformers include Low Voltage Directive 2006/95/EC and Electromagnetic Compatibility (EMC) Directive 2004/108/EC.



FEATURES

Integrally molded terminal blocks with combination slotted/phillips screws. Isolation barriers protect against arc over while able to accommodate a full ring terminal.



Integrally mounted fuse blocks available in standard and touch-proof (AE/CE Series) style.



Dual labels for identification of fused modules



AC/CE Series offers touch-proof terminals, isolating live contacts for additional safety.



Epoxy encapsulated copper windings and internal terminations, providing isolation from external contaminants and physical damage.



120 X 240 PRIMARY VOLTS — 24 SECONDARY VOLTS — 1Ø, 50/60 Hz

AE SERIES

VA Rating	Catalog Number	Approximate Dimensions (Inches)(Cm.)					Mounting Slot F	Approximate Ship Weight (Lbs.)(Kg.)
		A	B	C	D	E		
50	AE010050	2.69 (6.8)	3.00 (7.6)	2.81 (7.1)	2.03 (5.1)	2.53 (6.4)	.20 x .40 (0.5 x 1.0)	2.50 (1.1)
75	AE010075	3.22 (8.1)	3.00 (7.6)	2.81 (7.1)	2.53 (6.4)	2.53 (6.4)	.20 x .40 (0.5 x 1.0)	3.50 (1.6)
100	AE010100	3.28 (8.3)	3.41 (8.6)	3.09 (7.8)	2.41 (6.1)	2.81 (7.1)	.20 x .40 (0.5 x 1.0)	4.05 (1.8)
150	AE010150	3.88 (9.8)	3.78 (9.6)	3.41 (8.6)	2.97 (7.5)	3.13 (7.9)	.20 x .40 (0.5 x 1.0)	6.50 (2.9)
250	AE010250	4.13 (10.4)	4.50 (11.4)	3.84 (9.7)	2.94 (7.4)	3.75 (9.5)	.20 x .40 (0.5 x 1.0)	9.25 (4.2)
350	AE010350	5.00 (12.7)	4.50 (11.4)	3.84 (9.7)	3.78 (9.6)	3.75 (9.5)	.20 x .40 (0.5 x 1.0)	12.75 (5.8)
500	AE010500	5.53 (14.0)	5.25 (13.3)	4.66 (11.8)	4.16 (10.5)	4.38 (11.1)	.31 x .69 (0.8 x 1.7)	19.00 (8.6)
750	AE010750	6.81 (17.3)	5.25 (13.3)	4.66 (11.8)	5.75 (14.6)	4.38 (11.1)	.31 x .69 (0.8 x 1.7)	26.00 (11.8)

200/220/440, 208/230/460, 240/480 PRIMARY VOLTS — 23/110, 24/115, 25/120 SECONDARY VOLTS — 1Ø, 50/60 Hz

AE SERIES

VA Rating	Catalog Number	Approximate Dimensions (Inches)(Cm.)					Mounting Slot F	Approximate Ship Weight (Lbs.)(Kg.)
		A	B	C	D	E		
50	AE020050	3.28 (8.3)	3.00 (7.6)	2.78 (7.0)	2.25 (5.7)	2.53 (6.4)	.20 x .40 (0.5 x 1.0)	3.0 (1.4)
75	AE020075	3.28 (8.3)	3.00 (7.6)	3.09 (7.8)	2.53 (6.4)	2.81 (7.1)	.20 x .40 (0.5 x 1.0)	4.0 (1.8)
100	AE020100	3.28 (8.3)	3.41 (8.6)	3.41 (8.6)	2.53 (6.4)	3.13 (7.9)	.20 x .40 (0.5 x 1.0)	4.0 (1.8)
150	AE020150	4.03 (10.2)	3.75 (9.5)	3.41 (8.6)	3.28 (8.3)	3.13 (7.9)	.20 x .40 (0.5 x 1.0)	7.0 (3.2)
250	AE020250	4.38 (11.1)	4.50 (11.4)	4.03 (10.2)	3.75 (9.5)	3.75 (9.5)	.20 x .40 (0.5 x 1.0)	9.0 (4.1)
300	AE020300	5.13 (13.0)	4.50 (11.4)	4.97 (12.6)	3.88 (9.8)	4.38 (11.1)	.31 x .69 (0.8 X 1.7)	11.0 (5.0)
350	AE020350	5.25 (13.3)	4.50 (11.4)	4.97 (12.6)	4.16 (10.5)	4.38 (11.1)	.31 x .69 (0.8 X 1.7)	13.0 (5.9)
500	AE020500	6.31 (16.0)	5.25 (13.3)	4.97 (12.6)	5.25 (13.3)	4.38 (11.1)	.31 x .69 (0.8 X 1.7)	19.0 (8.6)
750	AE020750	6.81 (17.3)	5.25 (13.3)	4.97 (12.6)	5.75 (14.6)	4.38 (11.1)	.31 x .69 (0.8 X 1.7)	27.0 (12.2)

208/230/460 PRIMARY VOLTS — 115 SECONDARY VOLTS — 1Ø, 50/60 Hz

AE SERIES

VA Rating	Catalog Number	Approximate Dimensions (Inches)(Cm.)					Mounting Slot F	Approximate Ship Weight (Lbs.)(Kg.)
		A	B	C	D	E		
50	AE070050	2.84 (7.2)	3.00 (7.6)	2.81 (7.1)	2.16 (5.4)	2.53 (6.4)	.20 x .40 (0.5 x 1.0)	2.6 (1.2)
100	AE070100	3.41 (6.6)	3.41 (8.6)	3.09 (7.8)	2.69 (6.8)	2.81 (7.1)	.20 x .40 (0.5 x 1.0)	4.2 (1.9)
150	AE070150	3.88 (9.8)	3.75 (9.5)	3.41 (8.6)	3.09 (7.8)	3.09 (7.8)	.20 x .40 (0.5 x 1.0)	6.7 (3.1)
250	AE070250	4.16 (10.5)	4.50 (11.4)	4.03 (10.2)	3.28 (8.3)	3.75 (9.5)	.20 x .40 (0.5 x 1.0)	9.5 (4.3)
350	AE070350	5.19 (13.1)	4.50 (11.4)	4.03 (10.2)	4.38 (11.1)	3.75 (9.5)	.20 x .40 (0.5 x 1.0)	13.4 (6.1)
500	AE070500	5.88 (14.9)	5.25 (13.3)	4.66 (11.8)	4.78 (12.1)	4.38 (11.1)	.31 x .69 (0.8 X 1.7)	19.0 (8.6)
750	AE070750	6.81 (17.3)	5.25 (13.3)	4.66 (11.8)	5.75 (14.6)	4.38 (11.1)	.31 x .69 (0.8 X 1.7)	27.0 (12.2)



230/460/575 PRIMARY VOLTS — 95/115 SECONDARY VOLTS — 1Ø, 50/60 Hz

AE SERIES

VA Rating	Catalog Number	Approximate Dimensions (Inches)(Cm.)					Mounting Slot F	Approximate Ship Weight (Lbs.)(Kg.)
		A	B	C	D	E		
50	AE120050	2.88 (7.3)	3.00 (7.6)	2.81 (7.1)	2.19 (5.5)	2.53 (6.4)	.20 x .40 (0.5 x 1.0)	2.6 (1.2)
100	AE120100	3.59 (9.1)	3.41 (8.6)	3.09 (7.8)	2.88 (7.3)	2.81 (7.1)	.20 x .40 (0.5 x 1.0)	4.2 (1.9)
150	AE120150	3.94 (10.0)	3.78 (9.6)	3.41 (8.6)	3.28 (8.3)	3.09 (7.8)	.20 x .40 (0.5 x 1.0)	6.8 (3.1)
250	AE120250	4.16 (10.5)	4.50 (11.4)	4.03 (10.2)	3.22 (8.1)	3.75 (9.5)	.20 x .40 (0.5 x 1.0)	9.5 (4.3)
350	AE120350	5.00 (12.7)	4.50 (11.4)	4.03 (10.2)	3.69 (9.3)	4.31 (10.9)	.20 x .40 (0.5 x 1.0)	13.2 (6.0)
500	AE120500	5.84 (14.8)	5.25 (13.3)	4.66 (11.8)	4.66 (11.8)	4.38 (11.1)	.31 x .69 (0.8 X 1.7)	19.2 (8.7)
750	AE120750	6.81 (17.3)	5.25 (13.3)	4.66 (11.8)	5.81 (14.7)	4.38 (11.1)	.31 x .69 (0.8 X 1.7)	27.0 (12.2)

240 X 480 PRIMARY VOLTS — 24 SECONDARY VOLTS — 1Ø, 50/60 Hz

AE SERIES

VA Rating	Catalog Number	Approximate Dimensions (Inches)(Cm.)					Mounting Slot F	Approximate Ship Weight (Lbs.)(Kg.)
		A	B	C	D	E		
50	AE030050	2.69 (6.8)	3.00 (7.6)	2.81 (7.1)	2.03 (5.1)	2.53 (6.4)	.20 x .40 (0.5 x 1.0)	2.5 (1.1)
75	AE030075	3.22 (8.1)	3.00 (7.6)	2.81 (7.1)	2.53 (6.4)	2.53 (6.4)	.20 x .40 (0.5 x 1.0)	3.5 (1.6)
100	AE030100	3.28 (8.3)	3.41 (8.6)	3.09 (7.8)	2.41 (6.1)	2.81 (7.1)	.20 x .40 (0.5 x 1.0)	4.0 (1.8)
150	AE030150	3.88 (9.8)	3.84 (9.7)	3.41 (8.6)	2.97 (7.5)	3.13 (7.9)	.20 x .40 (0.5 x 1.0)	6.5 (2.9)
250	AE030250	4.13 (10.4)	4.50 (11.4)	3.84 (9.7)	2.94 (7.4)	3.75 (9.5)	.20 x .40 (0.5 x 1.0)	9.2 (4.2)
350	AE030350	5.00 (12.7)	4.50 (11.4)	3.84 (9.7)	3.78 (9.6)	3.75 (9.5)	.20 x .40 (0.5 x 1.0)	12.7 (5.8)
500	AE030500	5.53 (14.0)	5.25 (13.3)	4.66 (11.8)	4.16 (10.5)	4.34 (11.0)	.31 x .69 (0.8 X 1.7)	19.0 (8.6)
750	AE030750	6.81 (17.3)	5.25 (13.3)	4.66 (11.8)	5.75 (14.6)	4.38 (11.1)	.31 x .69 (0.8 X 1.7)	26.0 (11.8)

240 X 480, 230 X 460, 220 X 440 PRIMARY VOLTS — 120/115/110 SECONDARY VOLTS — 1Ø, 50/60 Hz

AE SERIES

VA Rating	Catalog Number	Approximate Dimensions (Inches)(Cm.)					Mounting Slot F	Approximate Ship Weight (Lbs.)(Kg.)
		A	B	C	D	E		
50	AE060050	2.69 (6.8)	3.00 (7.6)	2.81 (7.1)	2.03 (5.1)	2.53 (6.4)	.20 x .40 (0.5 x 1.0)	2.5 (1.1)
75	AE060075	3.22 (8.1)	3.00 (7.6)	2.81 (7.1)	2.53 (6.4)	2.53 (6.4)	.20 x .40 (0.5 x 1.0)	3.5 (1.6)
100	AE060100	3.28 (8.3)	3.41 (8.6)	3.09 (7.8)	2.41 (6.1)	2.81 (7.1)	.20 x .40 (0.5 x 1.0)	4.0 (1.8)
150	AE060150	3.88 (9.8)	3.84 (9.7)	3.41 (8.6)	2.97 (7.5)	3.13 (7.5)	.20 x .40 (0.5 x 1.0)	6.5 (2.9)
250	AE060250	4.13 (10.4)	4.50 (11.4)	3.84 (9.7)	2.94 (7.4)	3.75 (9.5)	.20 x .40 (0.5 x 1.0)	9.2 (4.2)
350	AE060350	5.00 (12.7)	4.50 (11.4)	3.84 (9.7)	3.78 (9.6)	3.75 (9.5)	.20 x .40 (0.5 x 1.0)	12.7 (5.8)
500	AE060500	5.53 (14.0)	5.25 (13.3)	4.66 (11.8)	4.16 (10.5)	4.34 (11.0)	.31 x .69 (0.8 X 1.7)	19.0 (8.6)
750	AE060750	6.81 (17.3)	5.25 (13.3)	4.66 (11.8)	5.75 (14.6)	4.31 (10.9)	.31 x .69 (0.8 X 1.7)	26.0 (11.8)



120 X 240 PRIMARY VOLTS — 24 SECONDARY VOLTS — 1Ø, 50/60 Hz

CE SERIES

VA Rating	Catalog Number	Approximate Dimensions (Inches)(Cm.)					Mounting Slot F	Approximate Ship Weight (Lbs.)(Kg.)
		A	B	C	D	E		
50	CE010050	2.69 (6.8)	3.00 (7.6)	2.81 (7.1)	2.25 (5.7)	2.56 (6.5)	.20 x .40 (0.5 x 1.0)	2.5 (1.2)
75	CE010075	3.22 (8.1)	3.41 (8.6)	2.81 (7.1)	2.25 (5.7)	2.88 (7.3)	.20 x .40 (0.5 x 1.0)	3.5 (1.6)
100	CE010100	3.28 (8.3)	3.75 (9.5)	3.09 (7.8)	2.53 (6.4)	3.13 (7.9)	.20 x .40 (0.5 x 1.0)	4.2 (1.9)
150	CE010150	3.88 (9.8)	4.50 (11.4)	3.41 (8.6)	2.53 (6.4)	3.84 (9.7)	.20 x .40 (0.5 x 1.0)	6.6 (3.0)
250	CE010250	4.13 (10.4)	4.50 (11.4)	4.03 (10.2)	3.22 (8.1)	3.84 (9.7)	.20 x .40 (0.5 x 1.0)	9.4 (4.3)
350	CE010350	5.00 (12.7)	5.25 (13.3)	4.03 (10.2)	3.75 (9.5)	4.50 (11.4)	.31 x .69 (0.8 X 1.7)	13.0 (5.9)
500	CE010500	5.50 (13.9)	5.25 (13.3)	4.66 (11.8)	4.28 (10.8)	4.50 (11.4)	.31 x .69 (0.8 X 1.7)	19.1 (8.7)
750	CE010750	7.03 (17.8)	5.25 (13.3)	4.66 (11.8)	5.75 (14.6)	4.50 (11.4)	.31 x .69 (0.8 X 1.7)	26.6 (12.1)

200/220/440, 208/230/460, 240/480 PRIMARY VOLTS — 23/110, 24/115, 25/120 SECONDARY VOLTS — 1Ø, 50/60 Hz

CE SERIES

VA Rating	Catalog Number	Approximate Dimensions (Inches)(Cm.)					Mounting Slot F	Approximate Ship Weight (Lbs.)(Kg.)
		A	B	C	D	E		
50	CE020050	3.28 (8.3)	3.28 (8.3)	2.81 (7.1)	2.25 (5.7)	2.81 (7.1)	.20 x .40 (0.5 x 1.0)	2.7 (1.2)
100	CE020100	4.03 (10.2)	3.75 (9.5)	3.13 (7.9)	3.22 (8.1)	3.16 (8.0)	.20 x .40 (0.5 x 1.0)	4.3 (1.9)
150	CE020150	4.03 (10.2)	4.50 (11.4)	3.41 (8.6)	2.81 (7.1)	3.75 (9.5)	.20 x .40 (0.5 x 1.0)	6.8 (3.0)
250	CE020250	4.78 (12.1)	4.50 (11.4)	4.03 (10.2)	4.06 (10.3)	3.75 (9.5)	.20 x .40 (0.5 x 1.0)	9.7 (4.4)
350	CE020350	5.53 (14.0)	5.25 (13.3)	4.03 (10.2)	4.28 (10.8)	4.38 (11.1)	.31 x .69 (0.8 X 1.7)	13.5 (6.1)
500	CE020500	7.25 (18.4)	5.25 (13.3)	4.69 (11.9)	6.00 (15.2)	4.38 (11.1)	.31 x .69 (0.8 X 1.7)	19.6 (8.9)
750	CE020750	6.81 (17.3)	5.28 (13.4)	4.69 (11.9)	5.75 (14.6)	4.44 (11.2)	.31 x .69 (0.8 X 1.7)	27.0 (12.2)

208, 220/380/440, 230/400/460, 240/416/480 PRIMARY VOLTS — 85/100/110, 91/110/120, 95/115/125, 99/120/130 SECONDARY VOLTS — 1Ø, 50/60 Hz

CE SERIES

VA Rating	Catalog Number	Approximate Dimensions (Inches)(Cm.)					Mounting Slot F	Approximate Ship Weight (Lbs.)(Kg.)
		A	B	C	D	E		
50	CE050050	4.03 (10.2)	3.41 (8.6)	3.09 (7.8)	2.47 (6.2)	2.81 (7.1)	.20 x .40 (0.5 x 1.0)	2.7 (1.2)
150	CE050150	3.88 (9.8)	4.34 (11.0)	3.41 (8.6)	2.88 (7.3)	3.75 (9.5)	.20 x .40 (0.5 x 1.0)	6.7 (3.0)
250	CE050250	5.13 (13.0)	4.50 (11.4)	4.03 (10.2)	4.38 (11.1)	3.75 (9.5)	.20 x .40 (0.5 x 1.0)	9.5 (4.3)
350	CE050350	5.91 (15.0)	5.25 (13.3)	4.03 (10.2)	4.78 (12.1)	4.38 (11.1)	.31 x .69 (0.8 X 1.7)	13.3 (6.0)
500	CE050500	5.91 (15.0)	5.25 (13.3)	4.66 (11.8)	4.63 (11.7)	4.38 (11.1)	.31 x .69 (0.8 X 1.7)	19.0 (8.6)
750	CE050750	7.09 (18.0)	5.25 (13.3)	4.66 (11.1)	5.81 (14.7)	4.38 (11.1)	.31 x .69 (0.8 X 1.7)	27.0 (12.2)



240 X 480 PRIMARY VOLTS— 24 SECONDARY VOLTS — 1Ø, 50/60 Hz

CE SERIES

VA Rating	Catalog Number	Approximate Dimensions (Inches)(Cm.)					Mounting Slot F	Approximate Ship Weight (Lbs.)(Kg.)
		A	B	C	D	E		
50	CE030050	3.00 (7.6)	3.00 (7.6)	2.81 (7.1)	2.25 (5.7)	2.53 (6.4)	.20 x .40 (0.5 x 1.0)	2.5 (1.1)
75	CE030075	3.28 (8.3)	3.28 (8.3)	2.81 (7.1)	2.25 (5.7)	2.81 (7.1)	.20 x .40 (0.5 x 1.0)	3.5 (1.6)
100	CE030100	3.28 (8.3)	3.75 (9.5)	3.09 (7.8)	2.53 (6.4)	3.13 (7.9)	.20 x .40 (0.5 x 1.0)	4.0 (1.8)
150	CE030150	3.88 (9.8)	4.50 (11.4)	3.47 (8.8)	2.53 (6.4)	3.75 (9.5)	.20 x .40 (0.5 x 1.0)	6.5 (2.9)
250	CE030250	4.13 (10.4)	4.50 (11.4)	4.03 (10.2)	3.22 (8.1)	3.75 (9.5)	.20 x .40 (0.5 x 1.0)	9.2 (4.2)
350	CE030350	5.00 (12.7)	5.25 (13.3)	4.03 (10.2)	3.75 (9.5)	4.38 (11.1)	.31 x .69 (0.8 X 1.7)	12.7 (5.8)
500	CE030500	5.53 (14.0)	5.25 (13.3)	4.66 (11.8)	4.28 (10.8)	4.38 (11.1)	.31 x .69 (0.8 X 1.7)	19.0 (8.6)
750	CE030750	7.03 (17.8)	5.25 (13.3)	4.66 (11.8)	5.41 (13.7)	4.38 (11.1)	.31 x .69 (0.8 X 1.7)	26.0 (11.8)

240 X 480, 230 X 460, 220 X 440 PRIMARY VOLTS—120/115/110 SECONDARY VOLTS — 1Ø, 50/60 Hz

CE SERIES

VA Rating	Catalog Number	Approximate Dimensions (Inches)(Cm.)					Mounting Slot F	Approximate Ship Weight (Lbs.)(Kg.)
		A	B	C	D	E		
50	CE060050	3.41 (8.6)	3.00 (7.6)	2.81 (7.1)	2.53 (6.4)	2.53 (6.4)	.20 x .40 (0.5 x 1.0)	2.6 (1.2)
75	CE060075	3.41 (8.6)	3.28 (8.3)	2.81 (7.1)	2.53 (6.4)	2.81 (7.1)	.20 x .40 (0.5 x 1.0)	3.6 (1.6)
100	CE060100	3.41 (8.6)	3.75 (9.5)	3.09 (7.8)	2.53 (6.4)	3.13 (7.9)	.20 x .40 (0.5 x 1.0)	4.3 (1.9)
150	CE060150	3.88 (9.8)	4.50 (11.4)	3.47 (8.8)	2.53 (6.4)	3.75 (9.5)	.20 x .40 (0.5 x 1.0)	6.7 (3.0)
250	CE060250	4.13 (10.4)	4.50 (11.4)	4.03 (10.2)	3.22 (8.1)	3.75 (9.5)	.20 x .40 (0.5 x 1.0)	9.4 (4.3)
300	CE060300	4.53 (11.5)	4.50 (11.4)	4.03 (10.2)	3.75 (9.5)	3.75 (9.5)	.20 x .40 (0.5 x 1.0)	10.9 (4.9)
350	CE060350	5.00 (12.7)	5.25 (13.3)	4.03 (10.2)	3.75 (9.5)	4.38 (11.1)	.31 x .69 (0.8 X 1.7)	13.0 (5.9)
500	CE060500	6.00 (15.2)	5.25 (13.3)	4.66 (11.8)	4.78 (12.1)	4.38 (11.1)	.31 x .69 (0.8 X 1.7)	18.8 (8.5)
750	CE060750	6.81 (17.3)	5.25 (13.3)	4.66 (11.8)	5.75 (14.6)	4.38 (11.1)	.31 x .69 (0.8 X 1.7)	26.0 (11.8)

380/400/415 PRIMARY VOLTS— 110/220 SECONDARY VOLTS — 1Ø, 50/60 Hz

CE SERIES

VA Rating	Catalog Number	Approximate Dimensions (Inches)(Cm.)					Mounting Slot F	Approximate Ship Weight (Lbs.)(Kg.)
		A	B	C	D	E		
50	CE040050	3.53 (8.9)	3.00 (7.6)	2.81 (7.1)	2.53 (6.4)	2.53 (6.4)	.20 x .40 (0.5 x 1.0)	2.6 (1.2)
100	CE040100	3.53 (8.9)	3.75 (9.5)	3.22 (8.1)	2.53 (6.4)	3.13 (8.0)	.20 x .40 (0.5 x 1.0)	4.3 (1.9)
150	CE040150	3.53 (8.9)	4.34 (11.0)	3.41 (8.6)	2.53 (6.4)	3.75 (9.5)	.20 x .40 (0.5 x 1.0)	6.7 (3.0)
250	CE040250	4.03 (10.2)	4.50 (11.4)	4.22 (10.7)	3.22 (8.1)	3.75 (9.5)	.20 x .40 (0.5 x 1.0)	9.4 (4.3)
350	CE040350	4.91 (12.4)	4.50 (11.4)	4.22 (10.7)	4.06 (10.3)	3.75 (9.5)	.20 x .40 (0.5 x 1.0)	13.0 (5.9)
500	CE040500	6.00 (15.2)	5.25 (13.3)	4.69 (11.9)	4.78 (12.1)	4.38 (11.1)	.31 x .69 (0.8 X 1.7)	18.8 (8.5)
750	CE040750	6.81 (17.3)	5.25 (13.3)	4.69 (11.9)	5.75 (14.6)	4.38 (11.1)	.31 x .69 (0.8 X 1.7)	26.0 (11.8)



PRIMARY FUSE SIZING CHART
RECOMMENDED RATING FOR CURRENT LIMITING CLASS CC FUSES

VA	120 V	208 V	230 V	240 V	277 V	380 V	416 V	440 V	460 V	480 V	550 V	600 V
50	1.2	0.6	0.6	0.6	0.6	0.3	0.3	0.3	0.3	0.3	0.3	0.3
75	1.9	1.0	1.0	1.0	0.8	0.6	0.6	0.6	0.5	0.5	0.4	0.4
100	2.5	1.5	1.3	1.3	1.0	0.8	0.8	0.6	0.6	0.6	0.6	0.5
150	3.8	2.0	2.0	1.9	1.5	1.2	1.2	1.0	1.0	1.0	0.8	0.8
250	3.5	3.5	3.5	3.0	3.0	2.0	1.8	1.8	1.5	1.5	1.4	1.2
300	4.0	4.0	4.0	3.5	3.0	2.5	2.5	2.0	2.0	1.9	1.5	1.5
350	5.0	5.0	4.5	4.0	4.0	2.5	2.5	2.5	2.0	2.0	1.9	1.8
500	7.0	4.0	3.5	3.5	5.5	4.0	3.5	3.5	3.5	3.0	3.0	2.5
750	10.0	6.0	5.5	5.0	4.5	6.0	5.5	5.0	5.0	5.0	4.0	4.0

SECONDARY FUSE SIZING CHART
RECOMMENDED RATING FOR CURRENT LIMITING MIDGET FUSES

VA	24 V	85 V	91 V	99 V	100 V	110 V	115 V	120 V	125 V	130 V
50 VA	3.2	0.9	0.9	0.8	0.8	0.7	0.7	0.6	0.6	0.6
75 VA	5.0	1.4	1.2	1.2	1.2	1.0	1.0	1.0	1.0	0.8
100 VA	6.0	1.5	1.5	1.5	1.5	1.5	1.5	1.2	1.2	1.2
150 VA	10.0	2.5	2.5	2.5	2.5	2.0	2.0	2.0	2.0	1.5
250 VA	12.0	4.5	4.5	4.0	4.0	3.5	3.5	3.0	3.0	3.0
300 VA	15.0	5.5	5.5	5.0	5.0	4.5	4.5	4.0	4.0	3.5
350 VA	20.0	6.5	6.0	5.5	5.5	5.0	5.0	4.5	4.5	4.5
500 VA	25.0	9.0	9.0	8.0	8.0	7.0	7.0	6.0	6.0	6.0
750 VA	40.0	12.0	12.0	12.0	12.0	10.0	10.0	10.0	10.0	9.0

CONNECTION DETAILS FOR AE05 & CE05

H1-H2	H1-H3	H1-H4	X1-X2	X1-X3	X1-X4
208			85	100	110
220	380	440	91	110	120
230	400	460	95	115	125
240	416	480	99	120	130

FUSE KITS AND ACCESSORIES

Catalog Number	VA	Description	Approximate Ship Weight (Lbs.)(Kg.)
PL79920	50-750	Fuse Kit: Primary Fuse Block EIC Series (2 Class CC Blocks)	1.0 (0.5)
PL79921	150-750	Fuse Kit: Primary & Secondary Fuse Block EIC Series (2 Class CC and 1 Midget Blocks)	1.0 (0.5)
PL79922	50-750	Fuse Kit: Primary Fuse Block EIC Series CE Listed w/ Covers (2 Class CC Blocks)	1.0 (0.5)
PL79923	150-750	Fuse Kit: Primary & Secondary Fuse Block EIC Series CE Listed w/ Covers (2 Class CC and 1 Midget Blocks)	1.0 (0.5)
PL79924		Fuse Kit: Secondary Fuse 1/4" x 1-1/4" w/ARM	1.0 (0.5)
PL79925	50-350	Cover: Small Terminal Covers (Qty. 2)	1.0 (0.5)
PL79926	500 & 750	Cover: Large Terminal Covers (Qty. 2)	1.0 (0.5)
PL79927		Cover: Fuse Block Covers (Qty. 1)	1.0 (0.5)
PL79928	50-350	Link: Small Jumper Links (Qty. 2)	1.0 (0.5)
PL79929	500 & 750	Link: Large Jumper Links (Qty. 2)	1.0 (0.5)
PL79930	50-350	Fuse Kit: Secondary Fuse Midget w/ARM	1.0 (0.5)
PL79931	500 & 750	Fuse Kit: Secondary Fuse Midget w/ARM	1.0 (0.5)

AE AND CE WIRING DIAGRAMS

WIRING FOR AE01 & CE01

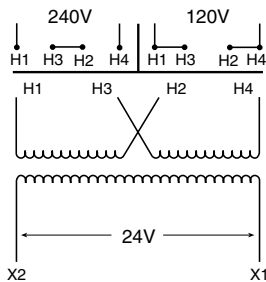

WIRING FOR AE02 & CE02

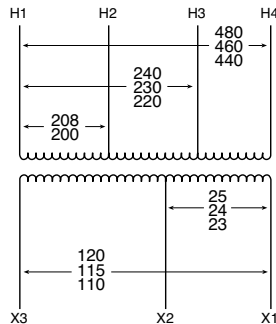

WIRING FOR AE03 & CE03

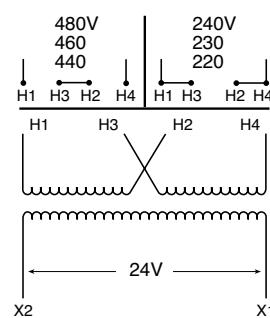

WIRING FOR CE04

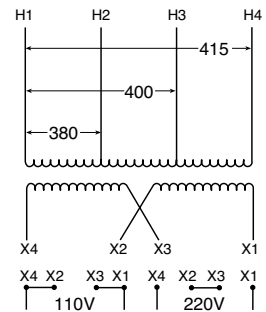

WIRING FOR AE05 & CE05

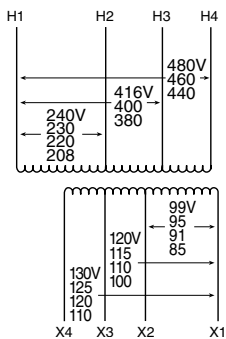

WIRING FOR AE06 & CE06

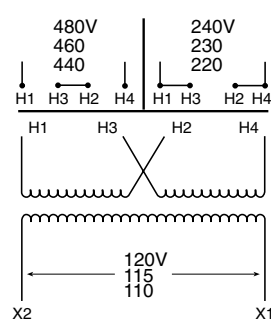

WIRING FOR AE07

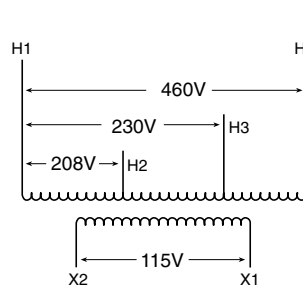

WIRING FOR AE 12

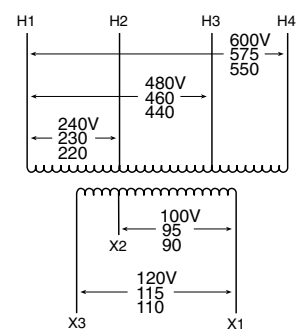

AE AND CE SERIES DIMENSIONAL DRAWINGS

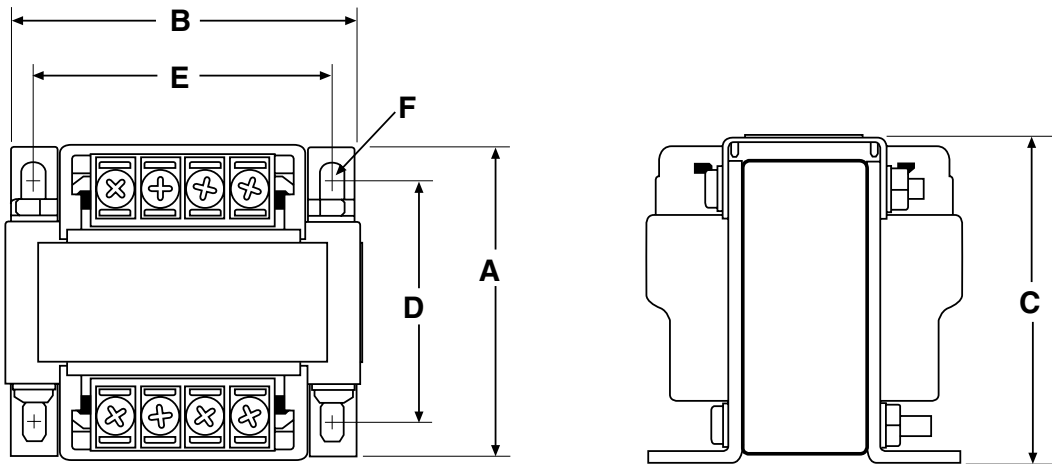

The Acme FINGER/GUARD® line of Touch-Protected Industrial Control Transformers offers the most advanced and versatile design concepts available to the marketplace today

They are designed to meet Acme's rigid standards for mechanical durability as well as surpass Agency and Industry electrical standards. The FINGER/GUARD® line is designed for all control applications and features integrally installed, durable molded plastic terminations designed to protect against contact with live components. No slip-on plastic covers to be broken, lost or misplaced.

All FINGER/GUARD® products use copper windings, high-permeability silicon steel cores and 130 degree C (Class B) insulation. All FINGER/GUARD® products meet or exceed ANSI, IEC and NEMA standards. They are third party witness tested and are UL Listed (File E79947), CSA Certified (File 7357) and CE Marked (to EN60742)...ON ALL SIZES. The product is suitable for both 50 and 60 Hertz applications and is available in sizes ranging from 50 VA to 3000 VA.

Features

- Constructed with high quality silicon steel lamination to minimize core losses and increase efficiency.
- Designs incorporate precision wound coils for improved regulation.
- Copper windings on all groups.
- 50 VA through 3000 VA sizes, 50/60 Hz.
- 130°C (Class B) Insulation 80°C temperature rise.
- Voltage regulation exceeds NEMA requirements.
- UL Listed, CSA Certified and CE Marked.
- Attractive finish, nameplate, and design features enhance the end product.
- Ten-year limited warranty.
- Smaller, lighter weight design.

CE MARKING Series for Global Applications

The CE Marking, standing for Conformité Européene, is a European Mark of conformity indicating that a product or system to which it is applied, complies with European law (Directives) regulating a necessary level of protection in Europe with respect to safety, health, environmental and consumer protection; however, it is not intended as a guarantee of quality for the consumer. The CE Marking must be applied to products being placed on the European market. The CE Marking does allow a product to be moved freely within the internal market of the European Union.

The Directives that apply to Control or Power Distribution Transformers are:

- Low Voltage Directive, 2006/95/EC
- Electromagnetic Compatibility (EMC) Directive, 2004/108/EC

The stringent testing required to obtain a third party certification mark in many cases is significantly more rigid than domestic requirements. This ensures that not only the Acme FINGER/GUARD® product, but all of our CE Marked products are designed to meet a higher level of safety standards than non-CE Marked products.

All Acme transformers are manufactured in a facility certified by Underwriters Laboratories to ISO-9001.



Durable molded plastic terminal is designed for protection against contact with live components

Easy to read nameplate clearly identifies important data

Easy access front opening in terminal makes for fast wire connections with one screw

Wide range of primary and secondary voltages





120 X 240 PRIMARY VOLTS — 24 SECONDARY VOLTS — 1Ø, 50/60 Hz

VA Rating	Catalog Number	European Rating*	Approximate Dimensions (Inches)(Cm.)					Mounting Slot F	Approximate Ship Weight (Lbs.)(Kg.)	Wiring Diagram
			A	B	C	D	E			
1000	FS11000	870	4.76 (12.1)	6.75 (17.1)	6.03 (15.3)	5.75 (14.6)	2.86 (7.3)	.31 x .50 (0.8 x 1.3)	26 (11.8)	A

240 X 480, 230 X 460, 220 X 440 PRIMARY VOLTS — 120/115/110 SECONDARY VOLTS — 1Ø, 50/60 Hz

VA Rating	Catalog Number	European Rating*	Approximate Dimensions (Inches)(Cm.)					Mounting Slot F	Approximate Ship Weight (Lbs.)(Kg.)	Wiring Diagram
			A	B	C	D	E			
1000	FS21000	870	4.76 (12.1)	6.75 (17.1)	6.03 (15.3)	5.75 (14.6)	2.86 (7.3)	.31 x .50 (0.8 x 1.3)	26 (11.8)	B
1500	FS21500	1290	6.01 (15.3)	6.75 (17.1)	6.03 (15.3)	5.75 (14.6)	4.13 (10.5)	.31 x .50 (0.8 x 1.3)	38 (17.2)	B
2000	FS22000	1680	6.51 (16.5)	6.75 (17.1)	6.03 (15.3)	5.75 (14.6)	4.63 (11.8)	.31 x .50 (0.8 x 1.3)	44 (20.0)	B
3000	FS23000	2465	7.44 (18.9)	7.50 (19.1)	6.68 (17.0)	6.50 (16.5)	6.47 (16.4)	.41 x .81 (1.0 x 2.1)	60 (27.2)	B





240/416/480/600; 230/400/460/575; 220/380/440/550; 208/500 PRIMARY VOLTS
 99/120/130; 95/115/125; 91/110/120; 85/100/110 SECONDARY VOLTS —1Ø, 50/60 Hz

VA Rating	Catalog Number	European Rating*	Approximate Dimensions (Inches/Cm.)					Mounting Slot	Approximate Ship Weight (Lbs.)(Kg.)	Wiring Diagram
			A	B	C	D	E			
50	FS350	50	2.59 (6.6)	3.75 (9.5)	3.64 (9.2)	3.13 (8.0)	1.70 (4.3)	.22 x .50 (0.6 x 1.3)	5 (2.3)	C
150	FS3150	150	3.31 (8.4)	4.50 (11.4)	4.15 (10.5)	3.75 (9.5)	2.18 (5.5)	.22 x .50 (0.6 x 1.3)	8 (3.6)	C
250	FS3250	250	3.61 (9.2)	4.88 (12.4)	4.46 (11.3)	4.06 (10.3)	2.33 (5.9)	.22 x .50 (0.6 x 1.3)	11 (5.0)	C
350	FS3350	345	4.69 (11.9)	4.88 (12.4)	4.46 (11.3)	4.06 (10.3)	3.48 (8.8)	.22 x .50 (0.6 x 1.3)	17 (7.7)	C
500	FS3500	490	4.39 (11.2)	6.75 (17.1)	6.03 (15.3)	5.75 (14.6)	2.48 (6.3)	.31 x .50 (0.8 x 1.3)	22 (10.0)	C
750	FS3750	720	5.18 (13.2)	6.75 (17.1)	6.03 (15.3)	5.75 (14.6)	3.31 (8.4)	.31 x .50 (0.8 x 1.3)	30 (13.6)	C
1000	FS31000	870	6.18 (15.7)	6.75 (17.1)	6.03 (15.3)	5.75 (14.6)	4.30 (10.9)	.31 x .50 (0.8 x 1.3)	39 (17.7)	C
1500	FS31500	1290	6.26 (15.9)	7.50 (19.1)	6.68 (17.0)	6.50 (16.5)	5.26 (13.4)	.41 x .81 (1.0 x 2.1)	51 (23.1)	C
2000	FS32000	1680	7.76 (19.7)	7.50 (19.1)	7.70 (19.6)	6.50 (16.5)	6.75 (17.1)	.41 x .81 (1.0 x 2.1)	66 (29.9)	C
3000	FS33000	2465	8.88 (22.6)	11.92 (30.3)	8.83 (22.4)	6.75 (17.1)	5.75 (14.6)	.41 x .81 (1.0 x 2.1)	70 (31.8)	C

FUSE KITS — FOR FINGER/GUARD® INDUSTRIAL CONTROL TRANSFORMERS

Catalog Number	Description
PL79905	PRIMARY FUSE KIT FOR CLASS CC FUSES
PL79906	PRIMARY & SECONDARY FUSE KIT FOR CLASS CC PRIMARY FUSES & MIDGET SECONDARY FUSE
PL79907	PRIMARY FUSE KIT FOR MIDGET FUSES
PL79908	PRIMARY & SECONDARY FUSE KIT FOR MIDGET FUSES

* EN60742 requires transformers to pass the temperature rise limits of a 130° C (Class B) insulation system at 6% above the rated supply voltage.

CONNECTION DETAILS WIRING DIAGRAM C

Connect to Line for Respective Voltage				Output Volts		
H1-H2	H1-H3	H1-H4	H1-H5	X1-X2	X1-X3	X1-X4
208	–	–	500	85	100	110
220	380	440	550	91	110	120
230	400	460	575	95	115	125
240	416	480	600	99	120	130

SECONDARY FUSE SIZING CHART
RECOMMENDED RATING FOR CURRENT LIMITING MIDGET FUSES

VA	24 V	85 V	91 V	99 V	100 V	110 V	115 V	120 V	125 V	130 V
50 VA	3.2	0.9	0.9	0.8	0.8	0.7	0.7	0.6	0.6	0.6
75 VA	5.0	1.4	1.2	1.2	1.2	1.0	1.0	1.0	1.0	1.0
100 VA	6.0	1.5	1.5	1.5	1.5	1.5	1.5	1.2	1.2	1.2
150 VA	10.0	2.5	2.5	2.5	2.5	2.0	2.0	2.0	2.0	2.0
250 VA	12.0	4.5	4.5	4.0	4.0	3.5	3.5	3.0	3.0	3.0
300 VA	15.0	5.5	5.5	5.0	5.0	4.5	4.5	4.0	4.0	4.0
350 VA	20.0	6.5	6.0	5.5	5.5	5.0	5.0	4.5	4.5	4.5
500 VA	25.0	9.0	9.0	8.0	8.0	7.0	7.0	6.0	6.0	6.0
750 VA	40.0	12.0	12.0	12.0	12.0	10.0	10.0	10.0	10.0	10.0
1000 VA	50.0	15.0	15.0	12.0	12.0	12.0	12.0	12.0	12.0	12.0
1500 VA	—	25.0	20.0	20.0	20.0	20.0	20.0	15.0	15.0	15.0
2000 VA	—	30.0	30.0	25.0	25.0	25.0	25.0	20.0	20.0	20.0
3000 VA	—	40.0	40.0	40.0	40.0	35.0	35.0	30.0	30.0	30.0

PRIMARY FUSE SIZING CHART
RECOMMENDED RATING FOR CURRENT LIMITING CLASS CC FUSES

VA	120 V	208 V	230 V	240 V	277 V	380 V	416 V	440 V	460 V	480 V	550 V	600 V
50	1.2	0.6	0.6	0.6	0.6	0.3	0.3	0.3	0.3	0.3	0.3	0.3
75	1.9	1.0	1.0	1.0	0.8	0.6	0.6	0.6	0.5	0.5	0.4	0.4
100	2.5	1.5	1.3	1.3	1.0	0.8	0.8	0.6	0.6	0.6	0.6	0.5
150	3.8	2.0	2.0	1.9	1.5	1.2	1.2	1.0	1.0	1.0	0.8	0.8
250	3.5	3.5	3.5	3.0	3.0	2.0	1.8	1.8	1.5	1.5	1.4	1.2
300	4.0	4.0	4.0	3.5	3.0	2.5	2.5	2.0	2.0	1.9	1.5	1.5
350	5.0	5.0	4.5	4.0	4.0	2.5	2.5	2.5	2.0	2.0	1.9	1.8
500	7.0	4.0	3.5	3.5	5.5	4.0	3.5	3.5	3.5	3.0	3.0	2.5
750	10.0	6.0	5.5	5.0	4.5	6.0	5.5	5.0	5.0	5.0	4.0	4.0
1000	15.0	8.0	7.0	7.0	6.0	4.5	4.0	3.5	3.5	3.5	5.5	5.0
1500	20.0	12.0	12.0	12.0	10.0	7.0	6.0	6.0	5.5	5.5	5.0	4.5
2000	25.0	12.0	15.0	15.0	12.0	9.0	8.0	8.0	7.5	7.0	6.0	6.0
3000	30.0	20.0	20.0	20.0	15.0	15.0	12.0	12.0	12.0	12.0	10.0	9.0

NOTE: Bold lines indicate changes in the percent of rated current used to calculate fuse sizes in accordance with article 450 of the NEC.

FINGER/GUARD® WIRING DIAGRAMS

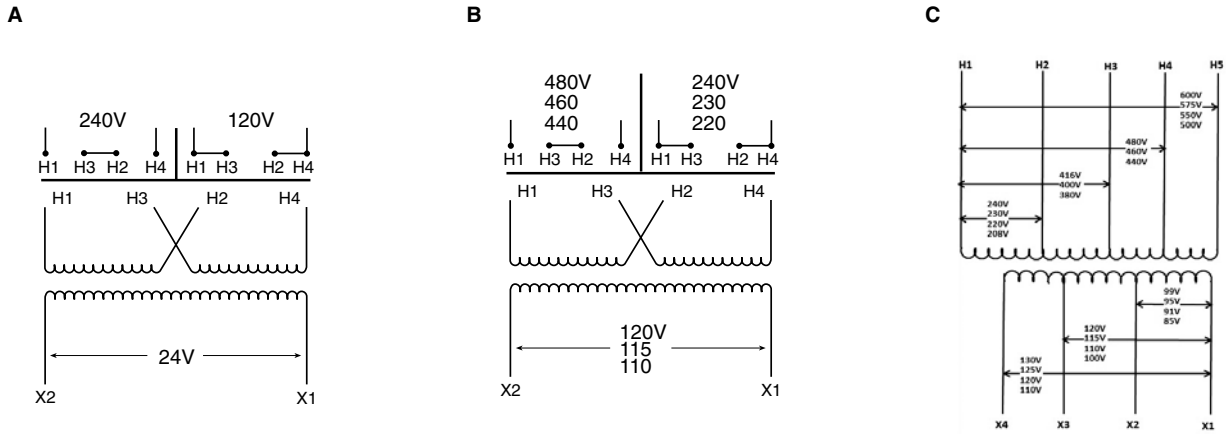

FINGER/GUARD® DIMENSIONAL DRAWINGS

50 VA THRU 2 KVA

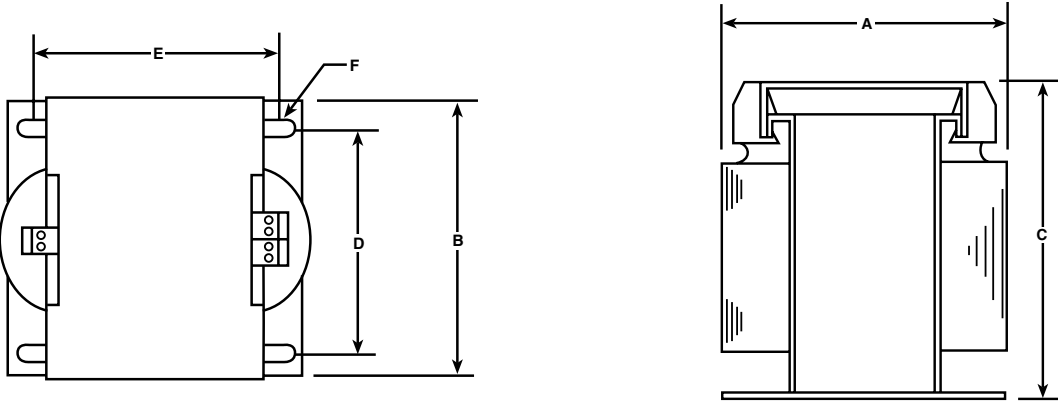

3 kVA

