



Harmonic Mitigating Transformers



Section

3



General Description and Features		46
Selection Charts		47

Many of today's electronic devices are non-linear loads generating high levels of harmonic currents that are then fed back onto your distribution system. This waveform distortion results in overheating of motors and transformers, increased neutral currents and malfunction/damage to other equipment on the line.

Acme Electric introduces a line of harmonic mitigating transformers that combine the technologies shown in our non-linear load (K-Factor) transformers. Where conventional K-Factor transformers "deal" with harmonics, containing them within the transformer and preventing them from going further upstream; harmonic mitigating transformers eliminate harmonics by pitting them against themselves. This technology not only results in "cleaner power" but also provides the most energy efficient means to deal with harmonic problems.

Available in sizes ranging from 30 thru 225 kVA, with copper windings and a variety of other design options and accessories, Acme harmonic mitigating transformers offer you reduced transformer heat, reduced voltage distortion due to 3rd order harmonics, and higher efficiency.

Features

- Unlike K-rated transformers, Harmonic Mitigating transformers actually treat the triplen harmonics in the secondary winding
- Reduce supply voltage flat topping caused by non-linear loads
- Improve overall power factor of supply system
- Suitable for K-Factor loads
- Improved energy efficiency
- Copper conductor construction

Applications

- Financial facilities
- Educational facilities
- TV Broadcast facilities
- Office buildings
- Hospitals
- Health care facilities

Dimensional Diagram

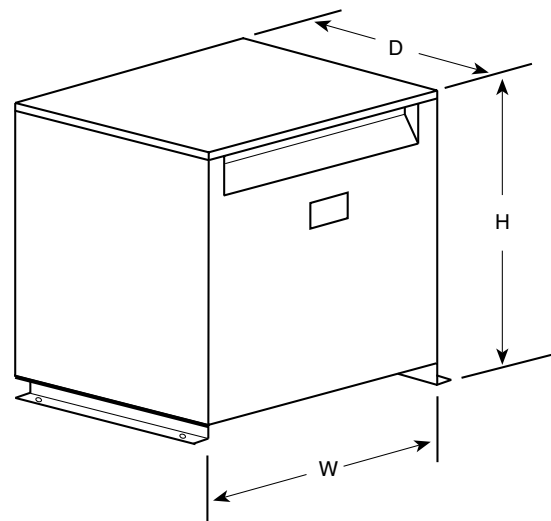



480 DELTA PRIMARY VOLTS — 208Y/120 SECONDARY VOLTS

kVA	Catalog Number	Height (Inches)(Cm.)	Width (Inches)(Cm.)	Depth (Inches)(Cm.)	Weight (Lbs.)(Kg.)	Mounting Type (Wall)(Floor)	Weather Shield	Wiring Diagrams	Design Figures
30.0	H3030K0014BCS	25.50 (64.8)	24.39 (61.9)	19.37 (49.2)	360 (163.2)	F ①	WSA1	81	E
45.0	H3045K0014BCS	25.50 (64.8)	24.39 (61.9)	19.37 (49.2)	500 (226.8)	F ①	WSA1	81	E
75.0	H3075K0014BCS	29.41 (74.7)	28.15 (71.5)	22.37 (56.8)	600 (272.2)	F ①	WSA2	81	E
112.5	H3112K0014BCS	35.47 (90.1)	31.90 (81.0)	26.88 (68.2)	938 (425.5)	F	WSA3	81	E
150.0	H3150K0014BCS	41.52 (105.5)	32.90 (83.5)	29.87 (75.9)	1213 (550.2)	F	WSA4	81	E
225.0	H3225K0014BCS	41.52 (105.5)	32.90 (83.5)	29.87 (75.9)	1872 (849.1)	F	WSA4	81	E

Notes: All models are DOE 2016 compliant

① Wall mounting brackets are available for these sizes, refer to page 217.

All Wiring Diagrams begin on page 209.

Harmonic Mitigating Transformers Wiring Diagram

81

PRIMARY: 480 Volts Delta
SECONDARY: 208Y/120 Volts
TAPS: 2, 2 1/2% ANFC, 2, 2 1/2% BNFC

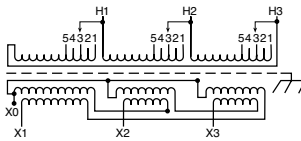

Primary Volts	Connect Primary Lines To	Inter-Connect	Connect Secondary Lines To
504	H1, H2, H3	1	
492	H1, H2, H3	2	
480	H1, H2, H3	3	
468	H1, H2, H3	4	
456	H1, H2, H3	5	
Secondary Volts			
208			X1, X2, X3
120 1 phase			X1 to X0 X2 to X0 X3 to X0

Diagram Showing Delta Primary and Zig-Zag Secondary

(Zero degree angular displacement)

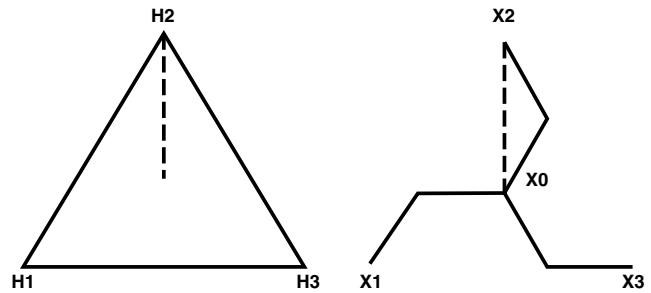

Harmonic Mitigating Transformers – How do they work?

They consist of a Delta primary and a Zig-Zag secondary. The Zig-Zag secondary causes a phase shift in the triplen harmonics, which results in a canceling effect. This prevents the triplen harmonic losses from being coupled back into the primary and results in cooler operation and increased energy efficiency.