



Dry-Type Distribution Transformers

Section

1



600 Volt Class and Below Single and Three Phase

Transformer Questions and Answers	6-13
Enclosure Definitions	13
Steps in Transformer Selection	14-17
Construction Features	18-20
Selection Charts, Single and Three Phase	21-32
Economical Auto Arrangements	33-34
Auto Zig-Zag Transformers	35
Non-Standard Three Phase Applications	36

1. What is a transformer and how does it work?

A transformer is an electrical apparatus designed to convert alternating current from one voltage to another. It can be designed to “step up” or “step down” voltages and works on the magnetic induction principle. A transformer has no moving parts and is a completely static solid state device, which insures, under normal operating conditions, a long and trouble-free life. It consists, in its simplest form, of two or more coils of insulated wire wound on a laminated steel core. When voltage is introduced to one coil, called the primary, it magnetizes the iron core. A voltage is then induced in the other coil, called the secondary or output coil. The change of voltage (or voltage ratio) between the primary and secondary depends on the turns ratio of the two coils.

2. What are taps and when are they used?

Taps are provided on some transformers on the high voltage winding to correct for high or low voltage conditions, and still deliver full rated output voltages at the secondary terminals. Standard tap arrangements are at two-and-one-half and five percent of the rated primary voltage for both high and low voltage conditions. For example, if the transformer has a 480 volt primary and the available line voltage is running at 504 volts, the primary should be connected to the 5% tap above normal in order that the secondary voltage be maintained at the proper rating. The standard ASA and NEMA designation for taps are “ANFC” (above normal full capacity) and “BNFC” (below normal full capacity).

3. What is the difference between Insulating, Isolating and Shielded Winding transformers?

Insulating and isolating transformers are identical. These terms are used to describe the isolation of the primary and secondary windings, or insulation between the two. A shielded transformer is designed with a metallic shield between the primary and secondary windings to attenuate transient noise. This is especially important in critical applications such as computers, process controllers and many other microprocessor controlled devices. All two, three and four winding transformers are of the insulating or isolating types. Only autotransformers, whose primary and secondary are connected to each other electrically, are not of the insulating or isolating variety.

4. Can transformers be operated at voltages other than nameplate voltages?

In some cases, transformers can be operated at voltages below the nameplate rated voltage. In NO case should a transformer be operated at a voltage in excess of its nameplate rating, unless taps are provided for this purpose. When operating below the rated voltage, the kVA capacity is reduced correspondingly. For example, if a 480 volt primary transformer with a 240 volt secondary is operated at 240 volts, the secondary voltage is reduced to 120 volts. If the transformer was originally rated 10 kVA, the reduced rating would be 5 kVA, or in direct proportion to the applied voltage.

5. Can 60 Hz transformers be operated at 50 Hz?

ACME transformers rated below 1 kVA can be used on 50 Hz service. Transformers 1 kVA and larger, rated at 60 Hz, should not be used on 50 Hz service, due to the higher losses and resultant heat rise. Special designs are required for this service. However, any 50 Hz transformer will operate on a 60 Hz service.

6. Can transformers be used in parallel?

Single phase transformers can be used in parallel only when their impedances and voltages are equal. If unequal voltages are used, a circulating current exists in the closed network between the two transformers, which will cause excess heating and result in a shorter life of the transformer. In addition, impedance values of each transformer must be within 7.5% of each other. For example: Transformer A has an impedance of 4%, transformer B which is to be parallel to A must have an impedance between the limits of 3.7% and 4.3%. When paralleling three phase transformers, the same precautions must be observed as listed above, plus the angular displacement and phasing between the two transformers must be identical.

7. Can Acme Transformers be reverse connected?

ACME dry-type distribution transformers can be reverse connected without a loss of kVA rating, but there are certain limitations. Transformers rated 1 kVA and larger single phase, 3 kVA and larger three phase can be reverse connected without any adverse effects or loss in kVA capacity. The reason for this limitation in kVA size is, the turns ratio is the same as the voltage ratio. Example: A transformer with a 480 volt input, 240 volt output can have the output connected to a 240 volt source and thereby become the primary or input to the transformer, then the original 480 volt primary winding will become the output or 480 volt secondary. On transformers rated below 1 kVA single phase, there is a turns ratio compensation on the low voltage winding. This means the low voltage winding has a greater voltage than the nameplate voltage indicates at no load. For example, a small single phase transformer having a nameplate voltage of 480 volts primary and 240 volts secondary, would actually have a no load voltage of approximately 250 volts, and a full load voltage of 240 volts. If the 240 volt winding were connected to a 240 volt source, then the output voltage would

consequently be approximately 460 volts at no load and approximately 442 volts at full load. As the kVA becomes smaller, the compensation is greater—resulting in lower output voltages. When one attempts to use these transformers in reverse, the transformer will not be harmed; however, the output voltage will be lower than is indicated by the nameplate.

8. Can a Single Phase Transformer be used on a Three Phase source?

Yes. Any single phase transformer can be used on a three phase source by connecting the primary leads to any two wires of a three phase system, regardless of whether the source is three phase 3-wire or three phase 4-wire. The transformer output will be single phase.

9. Can Transformers develop Three Phase power from a Single Phase source?

No. Phase converters or phase shifting devices such as reactors and capacitors are required to convert single phase power to three phase.

10. How do you select transformers?

- (1) Determine primary voltage and frequency.
- (2) Determine secondary voltage required.
- (3) Determine the capacity required in volt-amperes.

This is done by multiplying the load current (amperes) by the load voltage (volts) for single phase. For example: if the load is 40 amperes, such as a motor, and the secondary voltage is 240 volts, then 240×40 equals 9600 VA. A 10 kVA (10,000volt-amperes) transformer is required. ALWAYS SELECT THE TRANSFORMER LARGER THAN THE ACTUAL LOAD. This is done for safety purposes and allows for expansion, in case more load is added at a later date. For 3 phase kVA, multiply rated volts x load amps x 1.73 (square root of 3) then divide by 1000.

- (4) Determine whether taps are required. Taps are usually specified on larger transformers.
- (5) Use the selection charts in Section I.

11. What terminations are provided?

Primary and Secondary Terminations are provided on ACME Dry-Type Transformers as follows:

No lugs—lead type connection on
0-25 kVA single phase
0-15 kVA three phase encapsulated units

Bus-bar terminations (drilled to NEMA standards)
37.5 -250 kVA single phase
150-500 kVA three phase
Lugs 15-112.5 kVA three phase

12. Can 60 Hz transformers be used at higher frequencies?

ACME transformers can be used at frequencies above 60 Hz up through 400 Hz with no limitations provided nameplate voltages are not exceeded. However, 60 Hz transformers will have less voltage regulation at 400 Hz than 60 Hz.

13. What is meant by regulation in a transformer?

Voltage regulation in transformers is the difference between the no load voltage and the full load voltage. This is usually expressed in terms of percentage. For example: A transformer delivers 100 volts at no load and the voltage drops to 95 volts at full load, the regulation would be 5%. ACME dry-type distribution transformers generally have regulation from 2% to 4%, depending on the size and the application for which they are used.

14. What is temperature rise in a transformer?

Temperature rise in a transformer is the temperature of the windings and insulation above the existing ambient or surrounding temperature.

15. What is “Class” in insulation?

Insulation class was the original method used to distinguish insulating materials operating at different temperature levels. Letters were used for different designations. Letter classifications have been replaced by insulation system temperatures in degrees Celsius. The system temperature is the maximum temperature at the hottest spot in the winding (coil). Graphical representations of six insulation systems recognized by Underwriters' Laboratories, Inc. are shown in Figure A. These systems are used by Acme for a large part of the product line.

16. Is one insulation system better than another?

Not necessarily. It depends on the application and the cost benefit to be realized. Higher temperature class insulation systems cost more and larger transformers are more expensive to build. Therefore, the more expensive insulation systems are more likely to be found in the larger kVA units.

Referring to Figure A, small fractional kVA transformers use insulation class 130°C. Compound filled transformers use insulation class 180°C. Larger ventilated transformers are designed to use 220°C insulation. All of these insulation systems will normally have the same number of years operating life. A well designed transformer, observing these temperature limits, will have a life expectancy of 20-25 years.

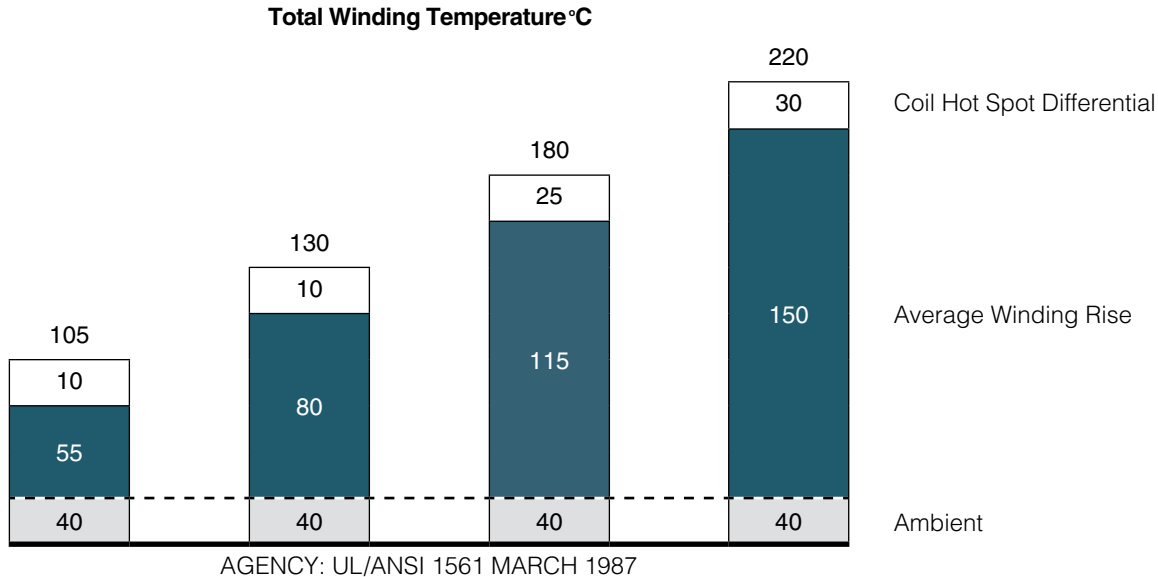

Figure A

17. Why should Dry-Type Transformers never be over-loaded ?

Overloading of a transformer results in excessive temperature. This excessive temperature causes overheating which will result in rapid deterioration of the insulation and cause complete failure of the transformer coils.

18. Are temperature rise and actual surface temperature related?

No. This can be compared with an ordinary light bulb. The filament temperature of a light bulb can exceed 2000 degrees, yet the surface temperature of the bulb is low enough to permit touching with bare hands.

19. What is meant by “impedance” in transformers?

Impedance is the current limiting characteristic of a transformer and is expressed in percentage.

20. Why is impedance important?

It is used for determining the interrupting capacity of a circuit breaker or fuse employed to protect the primary of a transformer. Example: Determine a minimum circuit breaker trip rating and interrupting capacity for a 10 kVA single phase transformer with 4% impedance, to be operated from a 480 volt 60 Hz source.

Calculate as follows:

$$\begin{aligned} \text{Normal Full Load Current} &= \frac{\text{Nameplate Volt Amps}}{\text{Line Volts}} = \frac{10,000 \text{ VA}}{480 \text{ V}} \\ &= 20.8 \text{ Amperes} \end{aligned}$$

$$\begin{aligned} \text{Maximum Short Circuit Amps} &= \frac{\text{Full Load Amps}}{4\%} = \frac{20.8 \text{ Amps}}{4\%} \\ &= 520 \text{ Amps} \end{aligned}$$

The breaker or fuse would have a minimum interrupting rating of 520 amps at 480 volts.

Example: Determine the interrupting capacity, in amperes, of a circuit breaker or fuse required for a 75 kVA, three phase transformer, with a primary of 480 volts delta and secondary of 208Y/120 volts. The transformer impedance (Z) = 5%. If the secondary is short circuited (faulted), the following capacities are required:

$$\begin{aligned} \text{Normal Full Load Current} &= \frac{\text{Volt Amps}}{\sqrt{3} \times \text{Line Volts}} = \frac{75,000 \text{ VA}}{\sqrt{3} \times 480 \text{ V}} \\ &= 90 \text{ Amps} \end{aligned}$$

$$\begin{aligned} \text{Maximum Short Circuit Amps} &= \frac{\text{Full Load Amps}}{5\%} = \frac{90 \text{ Amps}}{5\%} \\ &= 1,800 \text{ Amps} \end{aligned}$$

The breaker or fuse would have a minimum interrupting rating of 1,800 amps at 480 volts.

Note: The secondary voltage is not used in the calculation. The reason is the primary circuit of the transformer is the only winding being interrupted.

21. Can Single Phase Transformers be used for Three Phase applications?

Yes. Three phase transformers are sometimes not readily available whereas single phase transformers can generally be found in stock. Three single phase transformers can be used in delta connected primary and wye or delta connected secondary. They should never be connected wye primary to wye secondary, since this will result in unstable secondary voltage. The equivalent three phase capacity when properly connected of three single phase transformers is three times the nameplate rating of each single phase transformer. For example: Three 10 kVA single phase transformers will accommodate a 30 kVA three phase load.

22. Does ACME provide “Zig-Zag” Grounding Transformers?

Yes. Please refer to Page 35 for a special diagram which can be used to connect standard single phase off-the-shelf transformers in a three phase zig-zag manner. This system can be used for either grounding or developing a fourth wire from a three phase neutral. An example would be to change a 480 V — three phase — three wire system to a 480Y/277 V — three phase — four wire system.

23. What color are ACME Dry-Type Transformers?

ASA 61 (NEMA) light gray is used on all enclosed transformers from .050 to 1000 kVA.

24. How do you select a transformer to operate in an ambient higher than 40° centigrade?

When the ambient exceeds 40°C use the following chart for de-rating standard transformers.

Maximum Ambient Temperature	Maximum Percentage of Loading
40°C (104°F)	100%
50°C (122°F)	92%
60°C (140°F)	84%

Instead of ordering custom built transformers to operate in ambients higher than 40°C, it is more economical to use a standard transformer of a larger kVA rating.

25. Can transformers listed in this catalog be reconnected as autotransformers to increase their kVA rating?

Several standard single phase transformers listed in this catalog can be connected as autotransformers. The kVA capacity will be greatly increased when used as an autotransformer, in comparison to the nameplate kVA as an insulating transformer. Examples of autotransformer applications are changing 600 volts to 480 volts in either single phase or three phase; changing 480 volts to 240 volts single or three phase or vice versa; or the developing of a fourth wire (neutral) from a 480 volt three phase three wire system for obtaining 277 volts single phase. This voltage is normally used for operating fluorescent lamps or similar devices requiring 277 volts. For further details showing kVA and voltage combinations for various autotransformer connections refer to Page 33 and 34 in this catalog.

26. Are ACME Transformers shown in this catalog U.L. Listed?

All of the transformers, with few exceptions, are listed by Underwriters' Laboratories and have met their rigorous requirements. We are also prepared to have transformers, which are not presently listed, submitted for listing to Underwriters' upon the customer's request. Please contact the factory for details.

27. Is CSA certification available for transformers shown in this catalog?

Most ACME transformers shown in this catalog are certified by Canadian Standards Association. They have been designed and tested in accordance with the latest specifications. Please contact the factory if further details are required.

28. What is BIL and how does it apply to transformers listed in this catalog?

BIL is an abbreviation for Basic Impulse Level. Impulse tests are dielectric tests that consist of the application of a high frequency steep wave front voltage between windings, and between windings and ground. The Basic Impulse Level of a transformer is a method of expressing the voltage surge (lightning, switching surges, etc.) that a transformer will tolerate without breakdown. All transformers manufactured in this catalog, 600 volts and below, will withstand the NEMA standard BIL rating, which is 10 KV. This assures the user that he will not experience breakdowns when his system is properly protected with lightning arrestors or similar surge protection devices.

29. What is polarity, when associated with a transformer?

Polarity is the instantaneous voltage obtained from the primary winding in relation to the secondary winding. Transformers 600 volts and below are normally connected in additive polarity — that is, when tested the terminals of the high voltage and low voltage windings on the left hand side are connected together, refer to diagram below. This leaves one high voltage and one low voltage terminal unconnected. When the transformer is excited, the resultant voltage appearing across a voltmeter will be the sum of the high and low voltage windings. This is useful when connecting single phase transformers in parallel for three phase operations. Polarity is a term used only with single phase transformers.

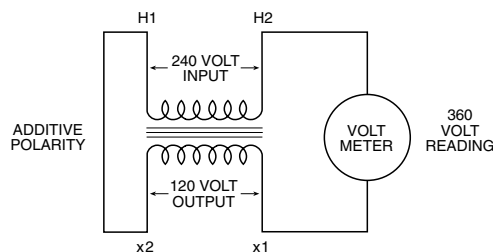

30. What is exciting current?

Exciting current, when used in connection with transformers, is the current or amperes required for excitation. The exciting current on most lighting and power transformers varies from approximately 10% on small sizes of about 1 kVA and smaller to approximately .5% to 4% on larger sizes of 750 kVA. The exciting current is made up of two components, one of which is a real component and is in the form of losses or referred to as no load watts; the other is in the form of reactive power and is referred to as kVAR.

31. Will a transformer change Three Phase to Single Phase?

A transformer will not act as a phase changing device when attempting to change three phase to single phase. There is no way that a transformer will take three phase in and deliver single phase out while at the same time presenting a balanced load to the three phase supply system. There are, however, circuits available to change three phase to two phase or vice versa using standard dual wound transformers. Please contact the factory for two phase applications.

32. Can air cooled transformers be applied to motor loads?

This is an excellent application for air cooled transformers. Even though the inrush or starting current is five to seven times normal running current, the resultant lower voltage caused by this momentary overloading is actually beneficial in that a cushioning effect on motor starting is the result. The tables on pages 15 and 17 illustrate some typical transformer requirements for use with motor applications.

33. How is an Acme Drive Isolation Transformer (DIT) different than a General Purpose Transformer?

DITs, as the name implies, are designed to be used with motor drives (AC and DC) and to provide isolation from the service line. They are specifically designed to withstand the “short circuit like” duty imposed by the firing of the thyristors. Harmonics generated by drives create added loads on the transformer. Therefore, it is important that a transformer of equal or greater kVA to that recommended by the drive manufacturer be installed for a particular motor application.

34. How are transformers sized to operate Three Phase induction type squirrel cage motors?

The minimum transformer kVA rating required to operate a motor is calculated as follows:

$$\text{Minimum Transformer kVA} = \frac{\text{Running Load Amperes} \times 1.73 \times \text{Motor Operating Voltage}}{1000}$$

Note: If motor is to be started more than once per hour add 20% additional kVA.

Care should be exercised in sizing a transformer for an induction type squirrel cage motor as when it is started, the lock rotor amperage is approximately 5 to 7 times the running load amperage. This severe starting overload will result in a drop of the transformer output voltage. When the voltage is low the torque and the horsepower of the motor will drop proportionately to the square of the voltage. For example: If the voltage were to drop to 70% of nominal, then motor horsepower and torque would drop to 70% squared or 49% of the motor nameplate rating.

If the motor is used for starting a high torque load, the motor may stay at approximately 50% of normal running speed as illustrated by the graph below:

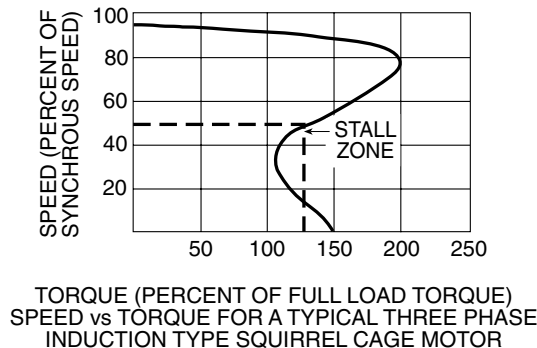

The underlying problem is low voltage at the motor terminals. If the ampere rating of the motor and transformer overcurrent device falls within the motor's 50% RPM draw requirements, a problem is likely to develop. The overcurrent device may not open under intermediate motor ampere loading conditions. Overheating of the motor and/or transformer would occur, possibly causing failure of either component.

This condition is more pronounced when one transformer is used to power one motor and the running amperes of the motor is in the vicinity of the full load ampere rating of the transformer. The following precautions should be followed:

- (1) When one transformer is used to operate one motor, the running amperes of the motor should not exceed 65% of the transformer's full load ampere rating.
- (2) If several motors are being operated from one transformer, avoid having all motors start at the same time. If this is impractical, then size the transformer so that the total running current does not exceed 65% of the transformer's full load ampere rating.

35. Why are Small Distribution Transformers not used for Industrial Control Applications?

Industrial control equipment demands a momentary overload capacity of three to eight times normal capacity. This is most prevalent in solenoid or magnetic contactor applications where inrush currents can be three to eight times as high as normal sealed or holding currents but still maintain normal voltage at this momentary overloaded condition. Distribution transformers are designed for good regulation up to 100 percent loading, but their output voltage will drop rapidly on momentary overloads of this type making them unsuitable for high inrush applications.

Industrial control transformers are designed especially for maintaining a high degree of regulation even at eight times normal load. This results in a larger and generally more expensive transformer. For a complete listing of ACME industrial control transformers, refer to Section 6.

36. Can 4-Winding Single Phase Transformer be auto-connected?

Yes. There are occasions where 480 volts single phase can be stepped down to 240 volts single phase by autoconnecting a standard 4-winding isolating transformer as shown in Figure 1. If connected in this manner, the nameplate kVA is doubled. For example: A 10 kVA load can be applied to a 5 kVA 4-winding transformer if connected per Figure 1.

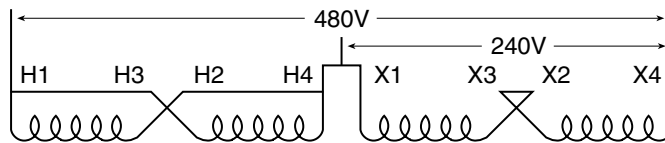

Figure 1

37. What about balanced loading on Three Phases?

Each phase of a three phase transformer must be considered as a single phase transformer when determining loading. For example: A 45 kVA three phase transformer with a 208Y/120 volt secondary is to service 4 loads at 120 volts single phase each.

These loads are 10 kVA, 5 kVA, 8 kVA, and 4 kVA.

Note: that maximum loading on any phase does not exceed 10 kVA. Each phase has a 15 kVA capacity.

$$\frac{45\text{kVA}}{3 \text{ phase}} = 15\text{kVA per phase}$$

If incorrect method is used, phase B will have an 18 kVA load which is 3 kVA above its normal capacity of 15 kVA and failure will result even though we only have a total load of 27 kVA on a 45 kVA transformer.

38. What is meant by “Balanced Loading” on Single Phase Transformer applications?

Since most single phase transformers have a secondary voltage of 120/240, they will be operated as a three wire system. Care must be taken in properly distributing the load as the transformer secondary consists of 2 separate 120 volt windings. Each 120 volt winding is rated at one-half the nameplate kVA rating. For example: A 10 kVA transformer, 120/240 volt secondary is to service an 8 kVA load at 240 volts and two 1 kVA loads at 120 volts each.

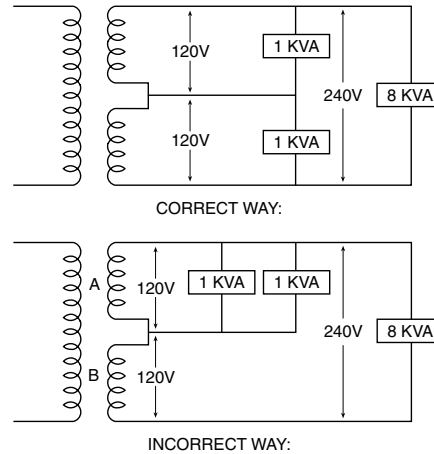
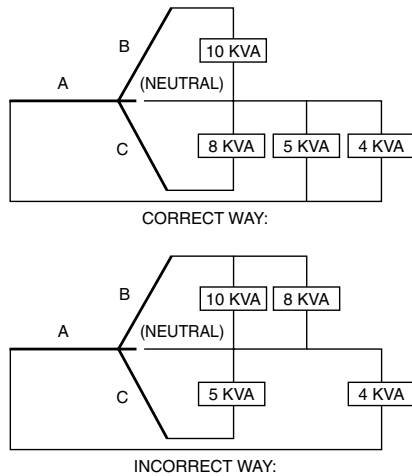

If the incorrect method is used, winding A will be loaded at 6 kVA, and winding B will be loaded at 4 kVA. These do total 10 kVA but, since each winding is only rated at 5 kVA (1/2 of nameplate rating), we have an overloaded transformer and a certain failure.

39. What are typical applications for transformers?

ACME transformers should be specified to:

- (1) Distribute power at high voltage.
- (2) Eliminate double wiring.
- (3) Operate 120 volt equipment from power circuits.
- (4) Insulate circuits/establish separately derived circuits.
- (5) Provide 3-wire secondary circuits.
- (6) Buck and Boost (See Section 8).
- (7) Provide electrostatic shielding for transient noise protection.

Enclosure Definitions

Type 1 Enclosures	Intended for indoor use, primarily to provide a degree of protection against contact with the enclosed equipment.
Type 2 Enclosures	Intended for indoor use, primarily to provide a degree of protection against limited amounts of falling water and dirt.
Type 3R Enclosures	Intended for outdoor use, primarily to provide a degree of protection against falling rain, sleet and external ice formation.

Definitions Pertaining to Enclosures

Ventilated	Constructed to provide for circulation of external air through the enclosure to remove excess heat, fumes or vapors.
Non-Ventilated	Constructed to provide no intentional circulation of external air through the enclosure.
Indoor Locations	Those areas protected from exposure to the weather.
Outdoor Locations	Those areas exposed to the weather.
Hazardous (Classified) Locations	Those areas, which may contain hazardous (classified) materials in sufficient quantity to create an explosion. See Article 500 of The National Electrical Code.

Single Phase Loads

1. Determine electrical load

- A. Voltage required by load.
- B. Amperes or kVA capacity required by load.
- C. Frequency in Hz (cycles per second).
- D. Verify load is designed to operate on a single phase supply.

All of the above information is standard data normally obtained from equipment nameplates or instruction manuals.

2. Determine supply voltage

- A. Voltage of supply (source).
- B. Frequency in Hz (cycles per second).

The frequency of the line supply and electrical load must be the same. Select single phase transformer designed to operate at this frequency, having a primary (input) equal to the supply voltage and a secondary (output) equal to the voltage required by the load.

3. If the load nameplate expresses a rating in kVA, a transformer can be directly selected from the charts. Choose from a group of transformers with primary and secondary voltages matching those you have just determined.

- A. Select a transformer with a standard kVA capacity **equal to or greater than** that needed to operate the load.
- B. Primary taps are available on most models to compensate for line voltage variations.
(Refer to question #2 in the Transformer Questions and Answers Section on page 6.)
- C. When load ratings are given only in amperes, tables 1 and 2 or the following formulas may be used to determine proper kVA size for the required transformer.
 - (1) To determine **kVA** when volts and amperes are known:

$$kVA = \frac{\text{Volts} \times \text{Amps}}{1000}$$

- (2) To determine **Amperes** when volts and amperes are known:

$$\text{Amps} = \frac{kVA \times 1000}{\text{Volts}}$$

Single Phase Example

Question: Select a transformer to meet the following conditions. Load is single phase lighting using incandescent lamps. Each fixture requires 1.3 amps @ 120 volts, 1 phase, 60 Hz, power factor of unity. The installation requires 52-100 watt fixtures. The desired circuit distributing power to the light fixtures is 120/240 volt, three wire, single phase. The supply voltage is 460 volt, 3 phase.

Answer: Compute the kVA required.

$$\frac{1.3 \text{ Amps} \times 120 \text{ V}}{3 \text{ phase}} = .156 \text{ kVA for each lighting fixture}$$

Always use amps x volts to compute VA, never use lamp wattage. .156 kVA/Fixture x 52 Fixture = 8.11 kVA. The two sizes (kVA) nearest 8.11 kVA are 7.5 kVA and 10 kVA. Use the 10 kVA. This will not overload the transformer and allows some capacity, 1.89 kVA, for future loads. Since the supply is 460 V (not 480 V) use the 456 V tap. This will produce approximately 120 volts on output. If the tap is not used, the output will be 115 V compared to the desired 120 V. Note the transformer selected is single phase but the supply is 480 V, 3 phase. Single phase is obtained by using any 2 wires of the 3 phase supply.

Table 1
Full Load Current in Amperes—
Single Phase Circuits

kVA	120V	208V	240V	277V	380V	440V	480V	600V
.050	0.4	0.2	0.2	0.2	0.1	0.1	0.1	0.1
.100	0.8	0.5	0.4	0.3	0.2	0.2	0.2	0.2
.150	1.2	0.7	0.6	0.5	0.4	0.3	0.3	0.3
.250	2.0	1.2	1.0	0.9	0.6	0.5	0.5	0.4
.500	4.2	2.4	2.1	1.8	1.3	1.1	1.0	0.8
.750	6.3	3.6	3.1	2.7	2.0	1.7	1.6	1.3
1	8.3	4.8	4.2	3.6	2.6	2.3	2.1	1.7
1.5	12.5	7.2	6.2	5.4	3.9	3.4	3.1	2.5
2	16.7	9.6	8.3	7.2	5.2	4.5	4.2	3.3
3	25	14.4	12.5	10.8	7.9	6.8	6.2	5.0
5	41	24.0	20.8	18.0	13.1	11.3	10.4	8.3
7.5	62	36	31	27	19.7	17	15.6	12.5
10	83	48	41	36	26	22.7	20.8	16.7
15	125	72	62	54	39	34	31	25
25	208	120	104	90	65	57	52	41
37.5	312	180	156	135	98	85	78	62
50	416	240	208	180	131	114	104	83
75	625	360	312	270	197	170	156	125
100	833	480	416	361	263	227	208	166
167	1391	802	695	602	439	379	347	278
250	2083	1203	1041	902	657	568	520	416

Table 2
Full Load Amperes
Single Phase A.C. Motors ①

Horsepower	115V	208V	230V	Minimum Transformer KVA
1/6	4.4	2.4	2.2	.53
1/4	5.8	3.2	2.9	.70
1/3	7.2	4.0	3.6	.87
1/2	9.8	5.4	4.9	1.18
3/4	13.8	7.6	6.9	1.66
1	16	8.8	8	1.92
1.5	20	11.0	10	2.40
2	24	13.2	12	2.88
3	34	18.7	17	4.10
5	56	30.8	28	6.72
7.5	80	44	40	9.6
10	100	55	50	12.0

① When motor service factor is greater than 1, increase full load amps proportionally. **Example:** If service factor is 1.15, increase above amp values by 15%.

$$1 \text{ Phase kVA} = \frac{\text{Volts} \times \text{Amps}}{1000}$$

Note: If motors are started more than once per hour, increase minimum transformer kVA by 20%.



Three Phase Loads

1. Determine electrical load

- A. Voltage required by load.
- B. Amperes or kVA required by load.
- C. Frequency in Hz (cycles per second).
- D. Verify load is designed to operate on three phase.

All the above information is standard data normally obtained from equipment nameplates or instruction manuals.

2. Determine supply voltage

- A. Voltage of supply (source).
- B. Frequency in Hz (cycles per second).

The frequency of the line supply and electrical load must be the same. A three phase transformer is selected which is designed to operate at this frequency having a primary (input) equal to the supply voltage and a secondary (output) equal to the voltage required by the load.

3. If the load nameplate expresses a rating in kVA, a transformer can be directly selected from the charts. Choose from the group of transformers with primary and secondary voltages matching that which you have just determined.

- A. Select a transformer with a standard kVA capacity **equal to or greater than** that needed to operate the load.
- B. Primary taps are available on most models to compensate for line voltage variations.
(Refer to question #2 in the Transformer Questions and Answers Section on page 6.)
- C. When load ratings are given only in amperes, tables 3 and 4 or the following formulas may be used to determine proper kVA size for the required transformer.
 - (1) To determine three phase **kVA** when volts and amperes are known:

$$\text{Three Phase kVA} = \frac{\text{Volts} \times \text{Amps} \times 1.73}{1000}$$

- (2) To determine **Amperes** when kVA and volts are known:

$$\text{Amps} = \frac{3 \text{ Phase kVA} \times 1000}{\text{Volts} \times 1.73}$$

Three Phase Example

Question: Select a transformer to fulfill the following conditions. Load is a three phase induction motor, 25 horsepower @ 240 volts, 60 Hz and a heater load of 4 kilowatts @ 240 volts single phase. The supply voltage is 480Y/277, three phase, 4 wire.

Answer: Compute the kVA required. **Motor**—From table 4 the current is 68 amps.

$$\frac{240 \text{ volts} \times 68 \text{ Amps} \times 1.73}{1000} = 28.2 \text{ kVA}$$

(The kVA can also be obtained from Table 4)

Heater — 4 kVA

A three phase transformer must be selected so that any one phase is not overloaded. Each phase should have the additional 4 kVA rating required by the heater even though the heater will operate on one phase only. So, the transformer should have a minimum kVA rating of 28.2 + 4 + 4 + 4 or 40.2 kVA. Refer to the appropriate selection chart. A 480 delta primary— 240 delta secondary transformer may be used on a 4 wire, 480Y/277 volt supply. The fourth wire (neutral) is not connected to the transformer. To not overload the transformer, a 45 kVA transformer should be selected.

Note: Any two wires of the 240 volts, 3 phase developed by the secondary of the transformer may be used to supply the heater. Any 2 wires of a 3 phase system is single phase.

Table 3
Full Load Current in Amperes—
Three Phase Circuits

kVA	208V	240V	380V	440V	480V	600V
3	8.3	7.2	4.6	3.9	3.6	2.9
4.5	12.5	10.8	6.8	5.9	5.4	4.3
6	16.6	14.4	9.1	7.8	7.2	5.8
9	25	21.6	13.7	11.8	10.8	8.6
15	41	36	22.8	19.6	18.0	14.4
22.5	62	54	34.2	29	27	21.6
30	83	72	45.6	39	36	28
45	124	108	68.4	59	54	43
75	208	180	114	98	90	72
112.5	312	270	171	147	135	108
150	416	360	228	196	180	144
225	624	541	342	294	270	216
300	832	721	456	392	360	288
500	1387	1202	760	655	601	481
750	2081	1804	1139	984	902	721
1000	2775	2405	1519	1312	1202	962

Table 4
Full Load Amperes
Three Phase A.C. Motors ①

Horsepower	208 V	230V	460V	575V	Minimum Transformer KVA
1/2	2.2	2.0	1.0	0.8	0.9
3/4	3.1	2.8	1.4	1.1	1.2
1	4.0	3.6	1.8	1.4	1.5
2	7.5	6.8	3.4	2.7	2.7
3	10.7	9.6	4.8	3.9	3.8
5	16.7	15.2	7.6	6.1	6.3
10	31	28	14	11	11.2
15	46	42	21	17	16.6
20	59	54	27	22	21.6
25	75	68	34	27	26.6
30	88	80	40	32	32.4
40	114	104	52	41	43.2
50	143	130	65	52	52
60	170	154	77	62	64
75	213	192	96	77	80
100	273	248	124	99	103
125	342	312	156	125	130
150	396	360	180	144	150
200	528	480	240	192	200

① When motor service factor is greater than 1, increase full load amps proportionally. **Example:** If service factor is 1.15, increase above amp values by 15%.

$$3 \text{ Phase kVA} = \frac{\text{Volts} \times \text{Amps} \times 1.73}{1000}$$

Note: If motors are started more than once per hour, increase minimum transformer kVA by 20%.



**Encapsulated
Single Phase, .05 to .150 kVA**

Features

- UL listed, CSA certified and UL-3R enclosure meets or exceeds all listing criteria including NEMA, ANSI and OSHA standards.
- Easy and convenient installation to meet your requirements, the transformer can be mounted in any position.
- Long Life UL class 130°C insulation system. Transformers can be banked for three phase service.
- Large wiring compartment, no conduit or pull boxes required. Front access for wiring ease. Wiring compartment remains cool.
- Completely enclosed UL-3R enclosure for indoor/outdoor service. Rugged non-ventilated construction.
- Plenty of knockouts for multi-directional entry.
- All copper lead wire terminations.
- Ground studs for use with non-metallic conduit.

**Encapsulated
Single Phase, .250 to 25 kVA**

- Installation keyhole mounting slots for mounting bolts prior to installation. Mounting slots are accessible from the front. Lifting ears are included on 3 to 25 kVA units.
- Wiring flexible copper leadwire terminations for easy connections outside the front access wiring compartment. Dual size knockouts in both sides and the bottom of the wiring compartment for greater wiring convenience and flexibility.

Features

- UL listed, CSA certified and UL-3R enclosures meets or exceeds all listing criteria including NEMA, ANSI and OSHA standards.
- Shielded for cleaner power.
- Encapsulated and completely enclosed design electrical grade silica and resin compounds completely enclose the core and coil to seal out all moisture and air. UL Type 3R enclosure for indoor or outdoor service. Encapsulation eliminates corrosion and insulation deterioration.
- Quiet operation with sound levels well below NEMA standards.
- Long life UL class 155°C insulation system. 115°C rise thru .750 kVA; 180°C insulation system, 115°C rise, 1 kVA and above.
- Available in 316 Stainless Steel and NEMA 4X enclosure.



Encapsulated**Three Phase, 3 to 75 kVA****Features**

- UL listed, CSA certified and UL-3R enclosure meets or exceeds all listing criteria including NEMA, ANSI and OSHA standards.
- UL Class 180°C insulation system. 115°C rise.
- Extra large front access wiring compartment through 9 kVA; top access through 75 kVA for easier installation and cooler case temperatures.
- Completely enclosed — suitable for indoor/outdoor service. Consult selection charts for details. Excellent for dust or lint laden atmosphere.
- Encapsulated — electrical grade silica and resin compound completely encloses the core and coil. Encapsulation seals out all moisture and air, eliminating corrosion and insulation deterioration.
- High efficiency and excellent regulation.
- Sound levels below NEMA standards.
- Keyhole mounting slots permit installation of mounting bolts prior to hanging transformer and are accessible from the front. Lifting ears for easy installation.
- Wiring connections can be made outside of wiring compartment due to the use of flexible leads.
- 3-9 kVA provided with dual size knockouts in sides and bottom of wiring compartment.
- Termination — copper lead wire.
- Electrostatic shielding provided on all 60 Hz isolation transformers.
- Available in 316 Stainless Steel.

316 Stainless Steel

- 3R enclosure.
- Encapsulated construction.
- Single phase: 0.25 – 25 kVA.
Three phase: 3 – 75 kVA.
- Core and Coil assembly completely encapsulated in polyester or epoxy seals out all moisture, eliminating corrosion and deterioration of insulation.
- Electrostatic shielding.

Applications

- Harsh industrial locations.
- Corrosive chemical exposure.
- Waste water treatment facilities.
- Coastal or marine applications with high salt mist.
- Any application where painted cold roll steel is not adequate.

Class 1 Division 2

- Encapsulated construction
- Three phase: 3 – 45kVA
- Groups A,B,C,D
- Temperature Class T3A
- Optional 316 Stainless Steel
- Electrostatic shielding



VENTILATED

Single Phase 37.5 to 250 kVA, Three Phase 15 to 1000 kVA

Features

- With weather shield, UL Type 3R enclosure or Type 2 enclosure without weather shield. UL listed and CSA certified.
- UL Class 220°C insulation system, 150°C rise.
- Extra large wiring compartment for easier installation and cooler case temperatures.
- NEMA standard bus bar terminals, no special tools needed to make clearly marked connections. Tap changing easily accomplished with jumpers.
- Aluminum windings for increased insulation life, cooler operation, lower losses.
- Noise and vibration isolating pads standard to assure quiet operation.
- Large permanently legible nameplates on front.
- Single phase units can be banked for 3 phase service.
- All units have ground studs for use with non-metallic conduit.
- Suitable for wall or “trapeze” mounting. Wall brackets are available for units up to 50 kVA single and 75 kVA three phase.
- Other models are available with class 220°C insulation and either 115°C or 80°C rise operating temperature.
- Three phase units 15-112.5 kVA have pre-installed lugs.

DOE

Three Phase 15 to 1000 kVA



Our new line of general purpose transformers not only meets but exceeds the new, more stringent DOE 2016 Energy Efficiency Standards.

Designed with feedback from our customers, the line is fully compatible in size with comparable transformers meeting the old 2007 TP-1 standards.

Replacing older general purpose transformers with our DOE 2016 compliant equipment will result in increased profitability from lower operating costs as well as a positive impact on the environment from a reduced carbon footprint.

Features:

- Core Design. Cores are high-quality electrical steel from industry-leading suppliers
- 3R Compliant. All new units ship with weather shields already installed
- Flexibility. When a weather shield is not needed, it can easily be removed
- Terminal Lugs. Primary and secondary terminals come standard with lugs (up to 112.5kVA) for quicker, easier connections
- Isolating Pads. Extra padding reduces noise and vibration, assuring quiet operation
- Aluminum Windings. Aluminum provides increased insulation life, cooler operation, and lower losses
- Consistent Fit/Form. Enclosure sizes of DOE 2016 units are identical to TP-1 sizes

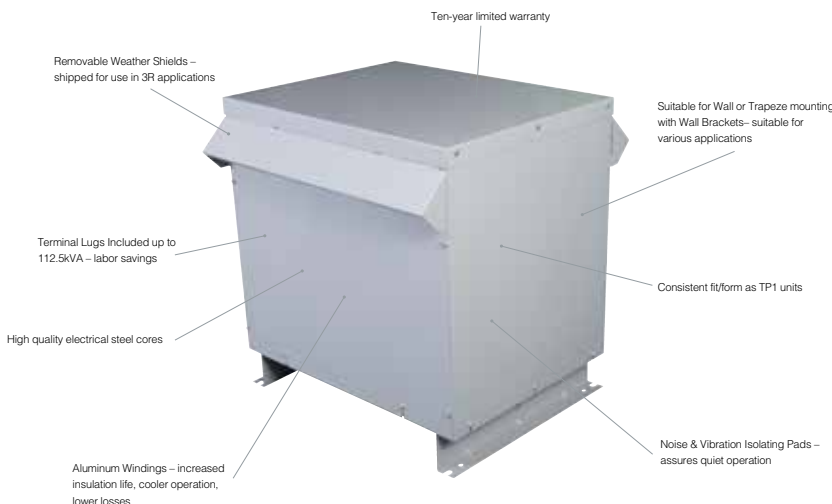

THREE PHASE EFFICIENCY STANDARD

kVA	TP1	DOE 2016
15	97.0%	97.89%
30	97.5%	98.23%
45	97.7%	98.40%
75	98.0%	98.60%
112.5	98.2%	98.74%
150	98.3%	98.83%
225	98.5%	98.94%
300	98.6%	99.02%
500	98.7%	99.14%
750	98.8%	99.23%
1000	98.9%	99.28%



SINGLE PHASE

120/208/240/277 PRIMARY VOLTS — 120/240 SECONDARY VOLTS — 1Ø, 60 Hz

kVA	Catalog Number	Height (Inches)(Cm.)	Width (Inches)(Cm.)	Depth (Inches)(Cm.)	Weight (Lbs.)(Kg.)	Mounting Type (Wall)(Floor)	Knockouts (Inches)(Cm.)	Weather Shield	Wiring Diagrams	Design Figures
1.0	T279740S	10.50 (26.7)	5.50 (14.0)	5.13 (13.0)	23 (10.4)	W	0.50-0.75 (1.3-1.9)	NA	23	B
1.5	T279741S	11.62 (29.5)	5.50 (14.0)	5.13 (13.0)	30 (13.6)	W	0.50-0.75 (1.3-1.9)	NA	23	B
2.0	T279742S	13.00 (33.0)	5.50 (14.0)	5.13 (13.0)	37 (16.8)	W	0.50-0.75 (1.3-1.9)	NA	23	B
3.0	T279743S	11.50 (29.2)	10.31 (26.2)	7.13 (18.1)	55 (24.9)	W	0.75-1.25 (1.9-3.2)	NA	23	C
5.0	T279744S	14.38 (36.5)	10.31 (26.2)	7.13 (18.1)	75 (34.0)	W	0.75-1.25 (1.9-3.2)	NA	23	C
7.5	T279745S	15.19 (38.6)	13.50 (34.3)	10.84 (27.5)	105 (47.6)	W	0.75-1.25 (1.9-3.2)	NA	63	D
10.0	T279746S	15.19 (38.6)	13.50 (34.3)	10.84 (27.5)	124 (56.2)	W	0.75-1.25 (1.9-3.2)	NA	63	D
15.0	T279747S	16.94 (43.0)	14.12 (35.9)	11.59 (29.4)	171 (77.6)	W	1.00-1.50 (2.5-3.8)	NA	63	D
25.0	T279748S	18.44 (46.8)	16.13 (41.0)	13.34 (33.9)	261 (118.4)	W	1.00-1.50 (2.5-3.8)	NA	63	D

190/200/208/220 X 380/400/416/440 PRIMARY VOLTS — 110/220 SECONDARY VOLTS — 1Ø, 50/60 Hz

EXPORT MODEL

kVA	Catalog Number	Height (Inches)(Cm.)	Width (Inches)(Cm.)	Depth (Inches)(Cm.)	Weight (Lbs.)(Kg.)	Mounting Type (Wall)(Floor)	Knockouts (Inches)(Cm.)	Weather Shield	Wiring Diagrams	Design Figures
*1.0	TF279300S	10.50 (26.7)	5.50 (14.0)	5.13 (13.0)	24 (10.9)	W	0.50-0.75 (1.3-1.9)	NA	65	B
*2.0	TF279301S	13.00 (33.0)	5.50 (14.0)	5.13 (13.0)	38 (17.2)	W	0.50-0.75 (1.3-1.9)	NA	65	B
*3.0	TF279302S	11.50 (29.2)	10.31 (26.2)	7.13 (18.1)	55 (24.9)	W	0.75-1.25 (1.9-3.2)	NA	65	C
*5.0	TF279303S	14.38 (36.5)	10.31 (26.2)	7.13 (18.1)	75 (34.0)	W	0.75-1.25 (1.9-3.2)	NA	65	C
*7.5	TF279304S	15.19 (38.6)	13.50 (34.3)	10.84 (27.5)	115 (52.2)	W	0.75-1.25 (1.9-3.2)	NA	65	D

*CE Marked

Maximum exciting current 5% at 50 Hz.

190/200/208/220 X 380/400/416/440 PRIMARY VOLTS — 120/240 SECONDARY VOLTS — 1Ø, 50/60 Hz

EXPORT MODEL

kVA	Catalog Number	Height (Inches)(Cm.)	Width (Inches)(Cm.)	Depth (Inches)(Cm.)	Weight (Lbs.)(Kg.)	Mounting Type (Wall)(Floor)	Knockouts (Inches)(Cm.)	Weather Shield	Wiring Diagrams	Design Figures
*1.0	TF217437S	10.50 (26.7)	5.50 (14.0)	5.13 (13.0)	24 (10.9)	W	0.50-0.75 (1.3-1.9)	NA	14	B
*2.0	TF217439S	13.00 (33.0)	5.50 (14.0)	5.13 (13.0)	38 (17.2)	W	0.50-0.75 (1.3-1.9)	NA	14	B
*3.0	TF249873S	11.50 (29.2)	10.31 (26.2)	7.13 (18.1)	55 (24.9)	W	0.75-1.25 (1.9-3.2)	NA	14	C
*5.0	TF252520S	14.38 (36.5)	10.31 (26.2)	7.13 (18.1)	75 (34.0)	W	0.75-1.25 (1.9-3.2)	NA	14	C
*7.5	TF252794S	15.19 (38.6)	13.50 (34.3)	10.84 (27.5)	115 (52.2)	W	0.75-1.25 (1.9-3.2)	NA	14	D
*10.0	TF252795S	15.19 (38.6)	13.50 (34.3)	10.84 (27.5)	125 (56.7)	W	0.75-1.25 (1.9-3.2)	NA	14	D
*15.0	TF252796S	16.94 (43.0)	14.12 (35.9)	11.59 (29.4)	170 (77.1)	W	1.00-1.50 (2.5-3.8)	NA	14	D
*25.0	TF252797S	18.44 (46.8)	16.13 (41.0)	13.34 (33.9)	300 (136.0)	W	1.00-1.50 (2.5-3.8)	NA	14	D

*CE Marked

All Wiring Diagrams begin on page 209.



190/208/220/240 X 380/416/440/480 PRIMARY VOLTS — 120/240 SECONDARY VOLTS — 1Ø, 50/60 Hz

EXPORT MODEL

kVA	Catalog Number	Height (Inches)(Cm.)	Width (Inches)(Cm.)	Depth (Inches)(Cm.)	Weight (Lbs.)(Kg.)	Mounting Type (Wall)(Floor)	Knockouts (Inches)(Cm.)	Weather Shield	Wiring Diagrams	Design Figures
*1.0	TF279260S	10.50 (26.7)	5.50 (14.0)	5.13 (13.0)	24 (10.9)	W	0.50-0.75 (1.3-1.9)	NA	64	B
*2.0	TF279261S	13.00 (33.0)	5.50 (14.0)	5.13 (13.0)	38 (17.2)	W	0.50-0.75 (1.3-1.9)	NA	64	B
*3.0	TF279262S	11.50 (29.2)	10.31 (26.2)	7.13 (18.1)	55 (24.9)	W	0.75-1.25 (1.9-3.2)	NA	64	C
*5.0	TF279263S	14.38 (36.5)	10.31 (26.2)	7.13 (18.1)	75 (34.0)	W	0.75-1.25 (1.9-3.2)	NA	64	C
*7.5	TF279264S	15.19 (38.6)	13.50 (34.3)	10.84 (27.5)	115 (52.2)	W	0.75-1.25 (1.9-3.2)	NA	64	D
*10.0	TF279265S	15.19 (38.6)	13.50 (34.3)	10.84 (27.5)	125 (56.7)	W	0.75-1.25 (1.9-3.2)	NA	64	D
*15.0	TF279266S	16.94 (43.0)	14.12 (35.9)	11.59 (29.4)	170 (77.1)	W	1.00-1.50 (2.5-3.8)	NA	64	D
*25.0	TF279267S	18.44 (46.8)	16.13 (41.0)	13.34 (33.9)	300 (136.1)	W	1.00-1.50 (2.5-3.8)	NA	64	D

*CE Marked

Maximum exciting current 5% at 50 Hz.

208 PRIMARY VOLTS — 120/240 SECONDARY VOLTS — THREE WINDINGS — 1Ø, 60 Hz

kVA	Catalog Number	Height (Inches)(Cm.)	Width (Inches)(Cm.)	Depth (Inches)(Cm.)	Weight (Lbs.)(Kg.)	Mounting Type (Wall)(Floor)	Knockouts (Inches)(Cm.)	Weather Shield	Wiring Diagrams	Design Figures
37.5	TP536491S	25.50 (64.8)	24.40 (62.0)	19.40 (49.3)	257 (117.0)	F ②	N/A	WSA1	58	E
50.0	TP536503S	25.50 (64.8)	24.40 (62.0)	19.40 (49.3)	340 (154.2)	F ②	N/A	WSA1	17	E
75.0	TP536513S	35.40 (89.9)	31.90 (81.0)	26.88 (68.2)	420 (190.5)	F	N/A	WSA3	17	E

Notes: 1.0 kVA through 25.0 kVA encapsulated (exempt from DOE 2016), 37.5 through 75 kVA DOE 2016 compliant

② Wall mounting brackets are available for these sizes, refer to page 217.

240 PRIMARY VOLTS — 120/240 SECONDARY VOLTS — 1Ø, 60 Hz

AUTO-TRANSFORMERS

kVA	Catalog Number	Height (Inches)(Cm.)	Width (Inches)(Cm.)	Depth (Inches)(Cm.)	Weight (Lbs.)(Kg.)	Mounting Type (Wall)(Floor)	Knockouts (Inches)(Cm.)	Weather Shield	Wiring Diagrams	Design Figures
1.0	T253060	9.06 (23.0)	4.37 (11.1)	4.20 (10.7)	15 (6.8)	W	0.50-0.75 (1.3-1.9)	NA	12	B
1.5	T253061	9.68 (24.6)	4.50 (11.4)	4.51 (11.5)	19 (8.6)	W	0.50-0.75 (1.3-1.9)	NA	12	B
2.0	T253062	10.50 (26.7)	5.50 (14.0)	5.13 (13.0)	24 (10.9)	W	0.50-0.75 (1.3-1.9)	NA	12	B
3.0	T253063	11.62 (29.5)	5.50 (14.0)	5.13 (13.0)	30 (13.6)	W	0.50-0.75 (1.3-1.9)	NA	12	B
5.0	T253064	13.00 (33.0)	5.50 (14.0)	5.13 (13.0)	38 (17.2)	W	0.50-0.75 (1.3-1.9)	NA	12	B
7.5	T253065	11.50 (29.2)	10.31 (26.2)	7.13 (18.1)	55 (24.9)	W	0.75-1.25 (1.9-3.2)	NA	12	C
10.0	T253066	15.19 (38.6)	13.50 (34.3)	10.84 (27.5)	115 (52.2)	W	0.75-1.25 (1.9-3.2)	NA	12	D
15.0	T253067	15.19 (38.6)	13.50 (34.3)	10.84 (27.5)	115 (52.2)	W	0.75-1.25 (1.9-3.2)	NA	12	D

All Wiring Diagrams begin on page 209.





240 X 480 PRIMARY VOLTS — 120/240 SECONDARY VOLTS — FOUR WINDINGS — 1Ø, 60 Hz

kVA	Catalog Number	Height (Inches)(Cm.)	Width (Inches)(Cm.)	Depth (Inches)(Cm.)	Weight (Lbs.)(Kg.)	Mounting Type (Wall)(Floor)	Knockouts (Inches)(Cm.)	Weather Shield	Wiring Diagrams	Design Figures
.05 ①	T153004	6.41 (16.3)	3.14 (8.0)	3.05 (7.7)	4 (1.8)	W	0.875 (2.2)	NA	1	A
.10 ①	T153005	7.16 (18.2)	3.89 (9.9)	3.67 (9.3)	5 (2.3)	W	0.875 (2.2)	NA	1	A
.15 ①	T153006	7.16 (18.2)	3.89 (9.9)	3.67 (9.3)	7 (3.2)	W	0.875 (2.2)	NA	1	A
.25 ①	T253007S	8.68 (22.0)	4.08 (10.4)	3.88 (9.9)	10 (4.5)	W	0.50-0.75 (1.3-1.9)	NA	2	B
.50 ①	T253008S	9.06 (23.0)	4.37 (11.1)	4.20 (10.7)	15 (6.8)	W	0.50-0.75 (1.3-1.9)	NA	2	B
.75 ①	T253009S	9.68 (24.6)	4.75 (12.1)	4.50 (11.4)	19 (8.6)	W	0.50-0.75 (1.3-1.9)	NA	2	B
1.00	T253010S	10.50 (26.7)	5.50 (14.0)	5.13 (13.0)	24 (10.9)	W	0.50-0.75 (1.3-1.9)	NA	2	B
1.50	T253011S	11.62 (29.5)	5.50 (14.0)	5.13 (13.0)	30 (13.6)	W	0.50-0.75 (1.3-1.9)	NA	2	B
2.00	T253012S	13.00 (33.0)	5.50 (14.0)	5.13 (13.0)	38 (17.2)	W	0.50-0.75 (1.3-1.9)	NA	2	B
3.00	T253013S	11.50 (29.2)	10.31 (26.2)	7.13 (18.1)	55 (24.9)	W	0.75-1.25 (1.9-3.2)	NA	2	C
3.00	T2530134S	11.50 (29.2)	10.31 (26.2)	7.13 (18.1)	55 (24.9)	W	0.75-1.25 (1.9-3.2)	NA	3	C
5.00	T253014S	14.38 (36.5)	10.31 (26.2)	7.13 (18.1)	75 (34.0)	W	0.75-1.25 (1.9-3.2)	NA	2	C
5.00	T2530144S	14.38 (36.5)	10.31 (26.2)	7.13 (18.1)	75 (34.0)	W	0.75-1.25 (1.9-3.2)	NA	3	C
7.50	T2535153S	15.19 (38.6)	13.50 (34.3)	10.84 (27.5)	115 (52.2)	W	0.75-1.25 (1.9-3.2)	NA	4	D
10.00	T2535163S	15.19 (38.6)	13.50 (34.3)	10.84 (27.5)	125 (56.7)	W	0.75-1.25 (1.9-3.2)	NA	4	D
15.00	T2535173S	16.94 (43.0)	14.12 (35.9)	11.59 (29.4)	170 (77.1)	W	1.00-1.50 (2.5-3.8)	NA	4	D
25.00	T2535183S	18.44 (46.8)	16.13 (41.0)	13.34 (33.9)	250 (113.0)	W	1.00-1.50 (2.5-3.8)	NA	4	D
37.50	TP530193S	25.50 (64.8)	24.39 (61.9)	19.37 (49.2)	280 (127.0)	F ②	NA	WSA1	5	E
50.00	TP530203S	25.50 (64.8)	24.39 (61.9)	19.37 (49.2)	350 (158.8)	F ②	NA	WSA1	5	E
75.00	TP530213S	35.47 (90.1)	31.90 (81.0)	26.88 (68.3)	430 (195.0)	F	NA	WSA3	5	E
100.00	TP530223S	41.52 (105.4)	32.90 (83.5)	29.87 (75.9)	525 (238.0)	F	NA	WSA4	5	E
167.00	TP530233S	45.60 (115.8)	39.50 (100.3)	35.50 (90.1)	1050 (476.3)	F	NA	WSA5	5	E
250.00	TP530243S	45.60 (115.8)	39.50 (100.3)	35.50 (90.1)	1440 (653.2)	F	NA	WSA5	5	E

Notes: 0.05 through 25.0 kVA encapsulated (exempt from DOE 2016), 37.5 through 250.0 kVA DOE 2016 compliant

① Suitable for 50/60Hz

② Wall mounting brackets are available for these sizes, refer to page 217.

240 X 480 PRIMARY VOLTS — 120/240 SECONDARY VOLTS — FOUR WINDINGS — 1Ø, 60 Hz

316 STAINLESS STEEL

kVA	Catalog Number	Height (Inches)(Cm.)	Width (Inches)(Cm.)	Depth (Inches)(Cm.)	Weight (Lbs.)(Kg.)	Mounting Type (Wall)(Floor)	Knockouts (Inches)(Cm.)	Weather Shield	Wiring Diagrams	Design Figures
0.25 ①	T253007SS	8.68 (22.0)	4.08 (10.4)	3.88 (9.9)	10 (4.5)	W	NA	NA	2	B
0.50 ①	T253008SS	9.06 (23.0)	4.37 (11.1)	4.20 (10.7)	15 (6.8)	W	NA	NA	2	B
0.75 ①	T253009SS	9.68 (24.6)	4.75 (12.1)	4.50 (11.4)	19 (8.6)	W	NA	NA	2	B
1.00	T253010SS	10.50 (26.7)	5.50 (14.0)	5.13 (13.0)	24 (10.9)	W	NA	NA	2	B
1.50	T253011SS	11.62 (29.5)	5.50 (14.0)	5.13 (13.0)	30 (13.6)	W	NA	NA	2	B
2.00	T253012SS	13.00 (33.0)	5.50 (14.0)	5.13 (13.0)	38 (17.2)	W	NA	NA	2	B
3.00	T253013SS	11.50 (29.2)	10.31 (26.2)	7.13 (18.1)	55 (24.9)	W	NA	NA	3	C
5.00	T253014SS	14.38 (36.5)	10.31 (26.2)	7.13 (18.1)	75 (34.0)	W	NA	NA	3	C
7.50	T253515SS	15.19 (38.6)	13.50 (34.3)	10.84 (27.5)	115 (52.2)	W	NA	NA	4	D
10.00	T253516SS	15.19 (38.6)	13.50 (34.3)	10.84 (27.5)	125 (56.7)	W	NA	NA	4	D
15.00	T253517SS	16.94 (43.0)	14.12 (35.9)	11.59 (29.4)	170 (77.1)	W	NA	NA	4	D
25.00	T253518SS	18.44 (46.8)	16.13 (41.0)	13.34 (33.9)	250 (113.0)	W	NA	NA	4	D

Notes: 0.25 through 25.0 kVA encapsulated (exempt from DOE 2016)

① Suitable for 50/60Hz

All Wiring Diagrams begin on page 209.



240 X 480 PRIMARY VOLTS — COPPER WINDINGS — 120/240 SECONDARY VOLTS — FOUR WINDINGS — 1Ø, 60 Hz

kVA	Catalog Number	Height (Inches)(Cm.)	Width (Inches)(Cm.)	Depth (Inches)(Cm.)	Weight (Lbs.)(Kg.)	Mounting Type (Wall)(Floor)	Knockouts (Inches)(Cm.)	Weather Shield	Wiring Diagrams	Design Figures
7.50	TC535153S	15.19 (38.6)	13.50 (34.3)	10.84 (27.5)	100 (45.4)	W	0.75-1.25 (1.9-3.2)	NA	4	D
10.00	TC535163S	15.19 (38.6)	13.50 (34.3)	10.84 (27.5)	120 (54.4)	W	0.75-1.25 (1.9-3.2)	NA	4	D
15.00	TC535173S	16.94 (43.0)	14.12 (35.9)	11.59 (29.4)	160 (72.6)	W	1.00-1.50 (2.5-3.8)	NA	4	D
25.00	TC535183S	18.44 (46.8)	16.13 (41.0)	13.34 (33.9)	250 (113.0)	W	1.00-1.50 (2.5-3.8)	NA	4	D
37.50	TPC530193S	25.50 (64.8)	24.39 (61.9)	19.37 (49.2)	295 (133.8)	F ②	NA	WSA1	5	E
50.00	TPC530203S	25.50 (64.8)	24.39 (61.9)	19.37 (49.2)	378 (172.0)	F ②	NA	WSA1	5	E

Notes: 7.5 through 25.0 kVA encapsulated (exempt from DOE 2016), 37.5 through 50.0 kVA DOE 2016 compliant

② Wall mounting brackets are available for these sizes, refer to page 217.

NON-VENTILATED TRANSFORMERS — 240 X 480 PRIMARY VOLTS — 120/240 SECONDARY VOLTS — FOUR WINDINGS — 1Ø, 60 Hz

kVA	Catalog Number	Height (Inches)(Cm.)	Width (Inches)(Cm.)	Depth (Inches)(Cm.)	Weight (Lbs.)(Kg.)	Mounting Type (Wall)(Floor)	Knockouts (Inches)(Cm.)	Weather Shield	Wiring Diagrams	Design Figures
37.50	TE2530193S	35.47 (90.1)	31.90 (81.0)	26.90 (68.3)	430 (195.0)	F ②	NA	NA	5	H
50.00	TE2530203S	35.47 (90.1)	31.90 (81.0)	26.90 (68.3)	430 (195.0)	F ②	NA	NA	5	H
75.00	TE2A530213S	35.47 (90.1)	31.90 (81.0)	26.90 (68.3)	525 (238.0)	F	NA	NA	5	H
100.00	TE1530223S	42.00 (106.7)	40.00 (101.6)	30.00 (76.2)	775 (352.0)	F	NA	NA	5	H

Notes: 37.5 through 100.0 kVA non-ventilated (exempt from DOE 2016)

② Wall mounting brackets are available for these sizes, refer to page 217.

277/480 PRIMARY VOLTS — 208/277 SECONDARY VOLTS — 1Ø, 60 Hz

kVA	Catalog Number	Height (Inches)(Cm.)	Width (Inches)(Cm.)	Depth (Inches)(Cm.)	Weight (Lbs.)(Kg.)	Mounting Type (Wall)(Floor)	Knockouts (Inches)(Cm.)	Weather Shield	Wiring Diagrams	Design Figures
0.25	GP12250S	8.68 (22.0)	4.08 (10.4)	3.88 (9.9)	12 (5.4)	W	0.50-0.75 (1.3-1.9)	NA	78	B
0.50	GP12500S	9.06 (23.0)	4.37 (11.1)	4.20 (10.7)	19 (8.6)	W	0.50-0.75 (1.3-1.9)	NA	78	B
1.00	GP121000S	10.50 (26.7)	5.50 (14.0)	5.13 (13.0)	30 (13.6)	W	0.50-0.75 (1.3-1.9)	NA	78	B
3.00	GP123000S	11.50 (29.2)	10.31 (26.2)	7.13 (18.1)	58 (26.3)	W	0.75-1.25 (1.9-3.2)	NA	78	C
5.00	GP125000S	14.38 (36.5)	10.31 (26.2)	7.13 (18.1)	80 (36.3)	W	0.75-1.25 (1.9-3.2)	NA	78	C
10.00	GP1210000S	15.19 (38.6)	13.50 (34.3)	10.84 (27.5)	125 (56.7)	W	0.75-1.25 (1.9-3.2)	NA	78	D
15.00	GP1215000S	16.94 (43.0)	14.12 (35.9)	11.59 (29.4)	161 (70.0)	W	1.00-1.50 (2.5-3.8)	NA	79	D

All Wiring Diagrams begin on page 209.



600 PRIMARY VOLTS — 120/240 SECONDARY VOLTS — THREE WINDINGS — 1Ø, 60 Hz

kVA	Catalog Number	Height (Inches)(Cm.)	Width (Inches)(Cm.)	Depth (Inches)(Cm.)	Weight (Lbs.)(Kg.)	Mounting Type (Wall)(Floor)	Knockouts (Inches)(Cm.)	Weather Shield	Wiring Diagrams	Design Figures
.05 ①	T153104	6.41 (16.3)	3.14 (8.0)	3.05 (7.7)	4 (1.8)	W	0.875 (2.2)	NA	8	A
.10 ①	T153105	7.16 (18.2)	3.89 (9.9)	3.67 (9.3)	5 (2.3)	W	0.875 (2.2)	NA	8	A
.15 ①	T153106	7.16 (18.2)	3.89 (9.9)	3.67 (9.3)	7 (3.2)	W	0.875 (2.2)	NA	8	A
.25 ①	T253107S	8.68 (22.0)	4.08 (10.4)	3.88 (9.9)	10 (4.5)	W	0.50-0.75 (1.3-1.9)	NA	9	B
.50 ①	T253108S	9.06 (23.0)	4.37 (11.1)	4.20 (10.7)	15 (6.8)	W	0.50-0.75 (1.3-1.9)	NA	9	B
.75 ①	T253109S	9.68 (24.6)	4.75 (12.1)	4.50 (11.4)	19 (8.6)	W	0.50-0.75 (1.3-1.9)	NA	9	B
1.00	T253110S	10.50 (26.7)	5.50 (14.0)	5.13 (13.0)	24 (10.9)	W	0.50-0.75 (1.3-1.9)	NA	9	B
1.50	T253111S	11.62 (29.5)	5.50 (14.0)	5.13 (13.0)	30 (13.6)	W	0.50-0.75 (1.3-1.9)	NA	9	B
2.00	T253112S	13.00 (33.0)	5.50 (14.0)	5.13 (13.0)	38 (17.2)	W	0.50-0.75 (1.3-1.9)	NA	9	B
3.00	T2531131S	11.50 (29.2)	10.31 (26.2)	7.13 (18.1)	55 (24.9)	W	0.75-1.25 (1.9-3.2)	NA	10	C
5.00	T2531141S	14.38 (36.5)	10.31 (26.2)	7.13 (18.1)	75 (34.0)	W	0.75-1.25 (1.9-3.2)	NA	10	C
7.50	T2536151S	15.19 (38.6)	13.50 (34.3)	10.84 (27.5)	115 (52.2)	W	0.75-1.25 (1.9-3.2)	NA	10	D
10.00	T2536161S	15.19 (38.6)	13.50 (34.3)	10.84 (27.5)	125 (56.7)	W	0.75-1.25 (1.9-3.2)	NA	10	D
15.00	T2536171S	16.94 (43.0)	14.12 (35.9)	11.59 (29.4)	170 (77.1)	W	1.00-1.50 (2.5-3.8)	NA	10	D
25.00	T2536181S	18.44 (46.8)	16.13 (41.0)	13.34 (33.9)	250 (113.0)	W	1.00-1.50 (2.5-3.8)	NA	10	D
37.50	TP531193S	25.50 (64.8)	24.40 (62.0)	19.40 (49.3)	275 (125.0)	F ②	NA	WSA1	11	E
50.00	TP531203S	29.90 (76.0)	28.15 (71.5)	22.37 (56.8)	340 (154.0)	F ②	NA	WSA2	11	E
75.00	TP531213S	35.47 (90.0)	31.90 (81.0)	26.88 (68.3)	430 (195.0)	F	NA	WSA3	11	E
100.00	TP531223S	41.52 (105.4)	32.90 (83.5)	29.87 (75.9)	525 (238.0)	F	NA	WSA4	11	E
167.00	TP531233S	45.60 (115.8)	39.5 (100.3)	35.5 (90.2)	1050 (476.3)	F	NA	WSA5	11	E

Notes: 0.05 kVA through 25.0 kVA encapsulated (exempt from DOE 2016), 37.5 through 167.0 kVA DOE 2016 compliant

① Suitable for 50/60Hz

② Wall mounting brackets are available for these sizes, refer to page 217.

All Wiring Diagrams begin on page 209.



THREE PHASE

190/200/208/220/230/240 DELTA PRIMARY VOLTS — 400Y/231 SECONDARY VOLTS — 3Ø, 60 Hz

kVA	Catalog Number	Height (Inches)(Cm.)	Width (Inches)(Cm.)	Depth (Inches)(Cm.)	Weight (Lbs.)(Kg.)	Mounting Type (Wall)(Floor)	Knockouts (Inches)(Cm.)	Optional Electrostatic Shield	Wiring Diagrams	Design Figures
15.0 ②	T379083S	18.86 (47.9)	20.30 (51.6)	9.03 (22.9)	300 (136.1)	F ①	NA	STD.	75	E
15.0	T3015K0170BS	25.50 (64.8)	24.39 (61.9)	19.37 (49.2)	300 (136.0)	F ①	NA	STD.	74	E
30.0	T3030K0170BS	25.50 (64.8)	24.39 (61.9)	19.37 (49.2)	360 (163.2)	F ①	NA	STD.	74	E
45.0	T3045K0170BS	25.50 (64.8)	24.39 (61.9)	19.37 (49.2)	675 (306.1)	F ①	NA	STD.	74	E
75.0	T3075K0170BS	29.41 (74.7)	28.15 (71.5)	22.37 (56.8)	600 (272.2)	F ①	NA	STD.	74	E

① Wall mounting brackets are available for these sizes, refer to page 217.

② DOE 2016 exempt, encapsulated unit

208 DELTA PRIMARY VOLTS — 208Y/120 SECONDARY VOLTS — 3Ø, 60 Hz

kVA	Catalog Number	Height (Inches)(Cm.)	Width (Inches)(Cm.)	Depth (Inches)(Cm.)	Weight (Lbs.)(Kg.)	Mounting Type (Wall)(Floor)	Knockouts (Inches)(Cm.)	Optional Electrostatic Shield	Wiring Diagrams	Design Figures
3.0 ②	T2A792681S	10.38 (26.4)	12.37 (31.4)	7.47 (19.0)	75 (34.0)	W	0.75-1.25 (1.9-3.2)	STD.	60	F
6.0 ②	T2A792691S	11.83 (30.0)	14.17 (36.0)	8.82 (22.4)	140 (63.5)	W	0.75-1.25 (1.9-3.2)	STD.	60	F
9.0 ②	T2A792701S	14.03 (36.0)	17.77 (45.1)	11.52 (29.3)	180 (81.6)	W	0.75-1.25 (1.9-3.2)	STD.	60	F
15.0 ②	T3792711S	18.86 (48.0)	20.30 (51.6)	9.03 (22.9)	245 (111.0)	F ①	NA	STD.	60	I
15.0	T3015K0064BS	25.50 (64.8)	24.39 (61.9)	19.37 (49.2)	300 (136.0)	F ①	NA	STD.	61	E
30.0	T3030K0064BS	25.50 (64.8)	24.39 (61.9)	19.37 (49.2)	360 (163.2)	F ①	NA	STD.	61	E
45.0	T3045K0064BS	25.50 (64.8)	24.39 (61.9)	19.37 (49.2)	441 (200.0)	F ①	NA	STD.	61	E
75.0	T3075K0064BS	29.41 (74.7)	28.15 (71.5)	22.37 (56.8)	600 (272.2)	F ①	NA	STD.	61	E

① Wall mounting brackets are available for these sizes, refer to page 217.

② DOE 2016 exempt, encapsulated unit

208 DELTA PRIMARY VOLTS — 480Y/277 SECONDARY VOLTS — 3Ø, 60 Hz

kVA	Catalog Number	Height (Inches)(Cm.)	Width (Inches)(Cm.)	Depth (Inches)(Cm.)	Weight (Lbs.)(Kg.)	Mounting Type (Wall)(Floor)	Knockouts (Inches)(Cm.)	Optional Electrostatic Shield	Wiring Diagrams	Design Figures
15.0 ②	T3793671S	18.86 (48.0)	20.30 (51.6)	9.03 (22.9)	245 (111.0)	F ①	NA	STD.	48	I
15.0	T3015K0034B	25.50 (64.8)	24.39 (61.9)	19.37 (49.2)	300 (136.0)	F ①	NA	YES ③	46	E
30.0	T3030K0034B	25.50 (64.8)	24.39 (61.9)	19.37 (49.2)	360 (163.2)	F ①	NA	YES ③	46	E
45.0	T3045K0034B	25.50 (64.8)	24.39 (61.9)	19.37 (49.2)	500 (226.8)	F ①	NA	YES ③	46	E
75.0	T3075K0034B	29.41 (74.7)	28.15 (71.5)	22.37 (56.8)	600 (272.2)	F ①	NA	YES ③	46	E
112.5	T3112K0034B	35.47 (90.1)	31.90 (81.0)	26.88 (68.2)	938 (425.5)	F	NA	YES ③	46	E
150.0	T3150K0034B	41.52 (105.4)	32.90 (83.5)	29.87 (75.9)	1188 (538.9)	F	NA	YES ③	46	E
225.0	T3225K0034B	41.52 (105.4)	32.90 (83.5)	29.87 (75.9)	1500 (680.4)	F	NA	YES ③	46	E
300.0	T3300K0034B	45.60 (115.8)	39.50 (100.3)	35.50 (90.1)	1938 (879.0)	F	NA	YES ③	46	E

① Wall mounting brackets are available for these sizes, refer to page 217.

② DOE 2016 exempt, encapsulated unit

③ Add "S" to part number

All Wiring Diagrams begin on page 209.



240 DELTA PRIMARY VOLTS — 208Y/120 SECONDARY VOLTS — 3Ø, 60 Hz

kVA	Catalog Number	Height (Inches)(Cm.)	Width (Inches)(Cm.)	Depth (Inches)(Cm.)	Weight (Lbs.)(Kg.)	Mounting Type (Wall)(Floor)	Knockouts (Inches)(Cm.)	Optional Electrostatic Shield	Wiring Diagrams	Design Figures
9.0 ②	T2A533601S	14.03 (36.0)	17.77 (45.1)	11.52 (29.3)	180 (81.6)	W	0.75-1.25 (1.9-3.2)	STD.	18	F
15.0 ②	T3533611S	18.86 (48.0)	20.30 (51.6)	9.03 (23.0)	250 (113.0)	F ①	NA	STD.	18	I
15.0	T3015K0044B	25.50 (64.8)	24.39 (61.9)	19.37 (49.2)	300 (136.0)	F ①	NA	YES ③	19	E
30.0	T3030K0044B	25.50 (64.8)	24.39 (61.9)	19.37 (49.2)	360 (163.2)	F ①	NA	YES ③	19	E
45.0	T3045K0044B	25.50 (64.8)	24.39 (61.9)	19.37 (49.2)	438 (198.6)	F ①	NA	YES ③	19	E
75.0	T3075K0044B	29.41 (74.7)	28.15 (71.5)	22.37 (56.8)	600 (272.2)	F ①	NA	YES ③	19	E
112.5	T3112K0044B	35.47 (90.1)	31.90 (81.0)	26.88 (68.2)	870 (394.6)	F	NA	YES ③	19	E
150.0	T3150K0044B	41.52 (105.4)	32.90 (83.5)	29.87 (75.9)	1223 (554.7)	F	NA	YES ③	19	E
225.0	T3225K0044B	41.52 (105.4)	32.90 (83.5)	29.87 (75.9)	1500 (680.4)	F	NA	YES ③	19	E

① Wall mounting brackets are available for these sizes, refer to page 217.

② DOE 2016 exempt, encapsulated unit

240 DELTA PRIMARY VOLTS — 480Y/277 SECONDARY VOLTS — 3Ø, 60 Hz

kVA	Catalog Number	Height (Inches)(Cm.)	Width (Inches)(Cm.)	Depth (Inches)(Cm.)	Weight (Lbs.)(Kg.)	Mounting Type (Wall)(Floor)	Knockouts (Inches)(Cm.)	Optional Electrostatic Shield	Wiring Diagrams	Design Figures
15.0 ②	T3796931S	18.90 (48.0)	20.30 (51.6)	9.00 (22.9)	245 (111.1)	F ①	NA	STD.	70	I
15.0	T3015K0074B	25.50 (64.8)	24.39 (61.9)	19.37 (49.2)	300 (136.0)	F ①	NA	YES ③	71	E
30.0	T3030K0074B	25.50 (64.8)	24.39 (61.9)	19.37 (49.2)	360 (163.2)	F ①	NA	YES ③	71	E
45.0	T3045K0074B	25.50 (64.8)	24.39 (61.9)	19.37 (49.2)	475 (215.5)	F ①	NA	YES ③	71	E
75.0	T3075K0074B	29.41 (74.7)	28.15 (71.5)	22.37 (56.8)	600 (272.2)	F ①	NA	YES ③	71	E
112.5	T3112K0074B	35.47 (90.1)	31.90 (81.0)	26.88 (68.2)	859 (389.6)	F	NA	YES ③	71	E
150.0	T3150K0074B	41.52 (105.4)	32.90 (83.5)	29.87 (75.9)	1216 (551.6)	F	NA	YES ③	71	E

① Wall mounting brackets are available for these sizes, refer to page 217.

② DOE 2016 exempt, encapsulated unit

③ Add "S" to part number

380 DELTA PRIMARY VOLTS — 220Y/127 SECONDARY VOLTS — 3Ø, 50 Hz

kVA	Catalog Number	Height (Inches)(Cm.)	Width (Inches)(Cm.)	Depth (Inches)(Cm.)	Weight (Lbs.)(Kg.)	Mounting Type (Wall)(Floor)	Knockouts (Inches)(Cm.)	Weather Shield	Wiring Diagrams	Design Figures
15.0	T3795511S	20.80 (52.8)	20.90 (53.1)	10.20 (25.9)	435 (197.3)	F	NA	NA	24	I
30.0	T2A795523S	25.50 (64.8)	24.40 (62.0)	19.40 (49.3)	365 (165.6)	F ①	NA	WSA1	20	E
45.0	T2A795533S	29.41 (74.7)	28.15 (71.5)	22.37 (56.8)	468 (212.3)	F ①	NA	WSA2	20	E
75.0	T2A795543S	35.47 (90.1)	31.90 (80.0)	26.88 (68.3)	693 (314.3)	F	NA	WSA3	20	E
112.5	T2A795553S	41.52 (105.4)	32.90 (83.5)	29.87 (75.9)	970 (440.0)	F	NA	WSA4	20	E

Notes: 50 Hz units (DOE 2016 exempt)

① Wall mounting brackets are available for these sizes, refer to page 217.

All Wiring Diagrams begin on page 209



440 DELTA PRIMARY VOLTS — 220Y/127 SECONDARY VOLTS — 3Ø, 50 Hz

kVA	Catalog Number	Height (Inches)(Cm.)	Width (Inches)(Cm.)	Depth (Inches)(Cm.)	Weight (Lbs.)(Kg.)	Mounting Type (Wall)(Floor)	Knockouts (Inches)(Cm.)	Weather Shield	Wiring Diagrams	Design Figures
10.0	TF220105S	18.90 (48.0)	20.30 (51.6)	9.00 (22.9)	245 (111.1)	F ①	NA	NA	73	I
15.0	TF220155S	25.50 (64.8)	24.40 (62.0)	19.40 (49.3)	291 (132.0)	F ①	NA	WSA1	73	E
25.0	TF220255S	25.50 (64.8)	24.40 (62.0)	19.40 (49.3)	375 (170.1)	F ①	NA	WSA1	73	E
50.0	TF220505S	29.41 (74.7)	28.15 (71.5)	22.37 (56.8)	437 (198.2)	F ①	NA	WSA2	73	E

Notes: 50 Hz units (DOE 2016 exempt)

① Wall mounting brackets are available for these sizes, refer to page 217.

480 DELTA PRIMARY VOLTS — 208Y/120 SECONDARY VOLTS — MAY BE USED ON A 4 WIRE 480Y/277 VOLTS SUPPLY— 3Ø, 60 Hz

kVA	Catalog Number	Height (Inches)(Cm.)	Width (Inches)(Cm.)	Depth (Inches)(Cm.)	Weight (Lbs.)(Kg.)	Mounting Type (Wall)(Floor)	Knockouts (Inches)(Cm.)	Optional Electrostatic Shield	Wiring Diagrams	Design Figures
3.0 ②	T2A533081S	10.38 (26.4)	12.37 (31.4)	7.47 (19.0)	75 (34.0)	W	0.75-1.25 (1.9-3.2)	STD.	21	F
6.0 ②	T2A533091S	11.83 (30.0)	14.17 (36.0)	8.82 (22.4)	140 (63.5)	W	0.75-1.25 (1.9-3.2)	STD.	21	F
9.0 ②	T2A533101S	14.03 (36.0)	17.77 (45.1)	11.52 (29.3)	180 (81.6)	W	0.75-1.25 (1.9-3.2)	STD.	21	F
15.0 ②	T3533111S	18.86 (48.0)	20.30 (51.6)	9.03 (22.9)	250 (113.0)	F ①	NA	STD.	21	I
15.0	T3015K0013B	25.50 (64.8)	24.39 (61.9)	19.37 (49.2)	300 (136.0)	F ①	NA	YES ③	22	E
30.0	T3030K0013B	25.50 (64.8)	24.39 (61.9)	19.37 (49.2)	360 (163.2)	F ①	NA	YES ③	22	E
45.0	T3045K0013B	25.50 (64.8)	24.39 (61.9)	19.37 (49.2)	500 (226.8)	F ①	NA	YES ③	22	E
75.0	T3075K0013B	29.41 (74.7)	28.15 (71.5)	22.37 (56.8)	600 (272.2)	F ①	NA	YES ③	22	E
112.5	T3112K0013B	35.47 (90.1)	31.90 (81.0)	26.88 (68.2)	938 (425.5)	F	NA	YES ③	22	E
150.0	T3150K0013B	41.52 (105.4)	32.90 (83.5)	29.87 (75.9)	1213 (550.2)	F	NA	YES ③	22	E
225.0	T3225K0013B	41.52 (105.4)	32.90 (83.5)	29.87 (75.9)	1500 (680.4)	F	NA	YES ③	22	E
300.0	T3300K0013B	45.60 (115.8)	39.50 (100.3)	35.50 (90.1)	1938 (879.0)	F	NA	YES ③	22	E
500.0	T3500K0013B	57.80 (147.0)	45.60 (115.8)	41.50 (105.4)	3100 (1406.1)	F	NA	YES ③	22	G
750.0	T3750K0013B	62.80 (159.5)	54.00 (137.1)	41.50 (105.4)	4500 (2041.1)	F	NA	YES ③	22	G
1000.0	T3001M0012B	62.80 (159.5)	54.00 (137.1)	41.50 (105.4)	5375 (2438.0)	F	NA	YES ③	80	G

① Wall mounting brackets are available for these sizes, refer to page 217.

② DOE 2016 exempt, encapsulated unit

③ Add "S" to part number

480 DELTA PRIMARY VOLTS — COPPER WINDINGS — 208Y/120 SECONDARY VOLTS — 3Ø, 60 Hz

kVA	Catalog Number	Height (Inches)(Cm.)	Width (Inches)(Cm.)	Depth (Inches)(Cm.)	Weight (Lbs.)(Kg.)	Mounting Type (Wall)(Floor)	Knockouts (Inches)(Cm.)	Optional Electrostatic Shield	Wiring Diagrams	Design Figures
15.0 ②	TC533111S	18.86 (48.0)	20.30 (51.6)	9.03 (22.9)	245 (111.0)	F ①	NA	STD.	21	I
15.0	T3015K0013BC	25.50 (64.8)	24.39 (61.9)	19.37 (49.2)	353 (160.1)	F ①	NA	YES ③	22	E
30.0	T3030K0013BC	25.50 (64.8)	24.39 (61.9)	19.37 (49.2)	498 (225.9)	F ①	NA	YES ③	22	E
45.0	T3045K0013BC	25.50 (64.8)	24.39 (61.9)	19.37 (49.2)	572 (259.5)	F ①	NA	YES ③	22	E
75.0	T3075K0013BC	29.41 (74.7)	28.15 (71.5)	22.37 (56.8)	750 (340.2)	F	NA	YES ③	22	E
112.5	T3112K0013BC	35.47 (90.1)	31.90 (81.0)	26.88 (68.2)	1103 (500.3)	F	NA	YES ③	22	E
150.0	T3150K0013BC	41.52 (105.4)	32.90 (83.5)	29.87 (75.9)	1477 (669.9)	F	NA	YES ③	22	E
225.0	T3225K0013BC	41.52 (105.4)	32.90 (83.5)	29.87 (75.9)	1872 (849.1)	F	NA	YES ③	22	E
300.0	T3300K0013BC	45.60 (115.8)	39.50 (100.3)	35.50 (90.1)	2233 (1012.9)	F	NA	YES ③	22	E
500.0	T3500K0013BC	57.80 (147.0)	45.60 (115.8)	41.50 (105.4)	4059 (1841.1)	F	NA	YES ③	22	G
750.0	T3750K0013BC	62.80 (159.5)	54.00 (137.1)	41.50 (105.4)	6192 (2808.6)	F	NA	YES ③	22	G

① Wall mounting brackets are available for these sizes, refer to page 217.

② DOE 2016 exempt, encapsulated unit, 115° C rise

③ Add "S" to part number

All Wiring Diagrams begin on page 209.



115° C RISE

480 DELTA PRIMARY VOLTS — 208Y/120 SECONDARY VOLTS — MAY BE USED ON A 4 WIRE 480Y/277 VOLTS SUPPLY— 3Ø, 60 Hz

kVA	Catalog Number	Height (Inches)(Cm.)	Width (Inches)(Cm.)	Depth (Inches)(Cm.)	Weight (Lbs.)(Kg.)	Mounting Type (Wall)(Floor)	Knockouts (Inches)(Cm.)	Optional Electrostatic Shield	Wiring Diagrams	Design Figures
15.0	T3015K0013BSF	25.50 (64.8)	24.39 (61.9)	19.37 (49.2)	300 (136.0)	F ①	NA	STD.	22	E
30.0	T3030K0013BSF	25.50 (64.8)	24.39 (61.9)	19.37 (49.2)	360 (163.3)	F ①	NA	STD.	22	E
45.0	T3045K0013BSF	25.50 (64.8)	24.39 (61.9)	19.37 (49.2)	500 (226.8)	F ①	NA	STD.	22	E
75.0	T3075K0013BSF	29.41 (74.7)	28.15 (71.5)	22.37 (56.8)	600 (272.2)	F ①	NA	STD.	22	E
112.5	T3112K0013BSF	35.47 (90.1)	31.90 (81.0)	26.88 (68.2)	938 (425.5)	F	NA	STD.	22	E
150.0	T3150K0013BSF	41.52 (105.4)	32.90 (83.5)	29.87 (75.9)	1213 (550.2)	F	NA	STD.	22	E
225.0	T3225K0013BSF	45.60 (115.8)	39.50 (100.3)	35.50 (90.1)	2298 (1042.3)	F	NA	STD.	22	E
300.0	T3300K0013BSF	45.60 (115.8)	39.50 (100.3)	35.50 (90.1)	2319 (1051.9)	F	NA	STD.	22	E
500.0	T3500K0013BSF	57.80 (147.0)	45.60 (115.8)	41.50 (105.4)	4156 (1885.1)	F	NA	STD.	22	G

① Wall mounting brackets are available for these sizes, refer to page 217.

80° C RISE

480 DELTA PRIMARY VOLTS — 208Y/120 SECONDARY VOLTS — MAY BE USED ON A 4 WIRE 480Y/277 VOLTS SUPPLY— 3Ø, 60 Hz

kVA	Catalog Number	Height (Inches)(Cm.)	Width (Inches)(Cm.)	Depth (Inches)(Cm.)	Weight (Lbs.)(Kg.)	Mounting Type (Wall)(Floor)	Knockouts (Inches)(Cm.)	Optional Electrostatic Shield	Wiring Diagrams	Design Figures
15.0	T3015K0013BSB	25.50 (64.8)	24.39 (61.9)	19.37 (49.2)	378 (171.5)	F ①	NA	STD.	22	E
30.0	T3030K0013BSB	25.50 (64.8)	24.39 (61.9)	19.37 (49.2)	550 (249.5)	F ①	NA	STD.	22	E
45.0	T3045K0013BSB	29.41 (74.7)	28.15 (71.5)	22.37 (56.8)	755 (342.5)	F	NA	STD.	22	E
75.0	T3075K0013BSB	35.47 (90.1)	31.90 (81.0)	26.88 (68.2)	1054 (478.1)	F	NA	STD.	22	E
112.5	T3112K0013BSB	41.52 (105.4)	32.90 (83.5)	29.87 (75.9)	1454 (659.5)	F	NA	STD.	22	E
150.0	T3150K0013BSB	41.52 (105.4)	32.90 (83.5)	29.87 (75.9)	1729 (784.3)	F	NA	STD.	22	E

For Copper wound transformers consult factory.

① Wall mounting brackets are available for these sizes, refer to page 217.

115° C RISE

480 DELTA PRIMARY VOLTS — 208Y/120 SECONDARY VOLTS — 3Ø, 60 Hz

ENCAPSULATED TRANSFORMERS

kVA	Catalog Number	Height (Inches)(Cm.)	Width (Inches)(Cm.)	Depth (Inches)(Cm.)	Weight (Lbs.)(Kg.)	Mounting Type (Wall)(Floor)	Knockouts (Inches)(Cm.)	Optional Electrostatic Shield	Wiring Diagrams	Design Figures
30.0	T3793123S	24.81 (63.0)	27.13 (68.9)	11.14 (28.3)	613 (278.1)	F	NA	STD.	22	I
45.0	T3793133S	25.31 (64.3)	30.18 (76.7)	12.76 (32.4)	780 (354.0)	F	NA	STD.	22	I
75.0	T3793143S	26.82 (68.1)	34.68 (88.1)	15.25 (38.7)	1126 (511.0)	F	NA	STD.	22	I

Notes: 30.0 through 75.0 kVA encapsulated (DOE 2016 exempt)

115° C RISE

480 DELTA PRIMARY VOLTS — 208Y/120 SECONDARY VOLTS — 3Ø, 60 Hz 316 STAINLESS STEEL ENCAPSULATED TRANSFORMERS

kVA	Catalog Number	Height (Inches)(Cm.)	Width (Inches)(Cm.)	Depth (Inches)(Cm.)	Weight (Lbs.)(Kg.)	Mounting Type (Wall)(Floor)	Knockouts (Inches)(Cm.)	Optional Electrostatic Shield	Wiring Diagrams	Design Figures
3.0	T2A53308SS	10.38 (26.4)	12.37 (31.4)	7.47 (19.0)	75 (34.0)	W	NA	STD.	21	F
6.0	T2A53309SS	11.83 (30.0)	14.17 (36.0)	8.82 (22.4)	140 (63.5)	W	NA	STD.	21	F
9.0	T2A53310SS	14.03 (35.6)	17.77 (45.1)	11.52 (29.3)	180 (81.6)	W	NA	STD.	21	F
15.0	T353311SS	18.86 (47.9)	20.30 (51.6)	9.03 (22.9)	250 (113.0)	F	NA	STD.	21	I
30.0	T379312SS	24.81 (63.0)	27.13 (68.9)	11.14 (28.3)	613 (278.1)	F	NA	STD.	22	I
45.0	T379313SS	25.31 (64.3)	30.18 (76.7)	12.76 (32.4)	780 (354.0)	F	NA	STD.	22	I
75.0	T379314SS	26.82 (68.1)	34.68 (88.1)	15.25 (38.7)	1126 (511.0)	F	NA	STD.	22	I

Notes: 3.0 through 75.0 kVA units encapsulated (DOE 2016 exempt)

All Wiring Diagrams begin on page 209.



480 DELTA PRIMARY VOLTS — 208Y/120 SECONDARY VOLTS — 3Ø, 60 Hz

CLASS 1 DIV. 2 TRANSFORMERS

kVA	Catalog Number	Height (Inches)(Cm.)	Width (Inches)(Cm.)	Depth (Inches)(Cm.)	Weight (Lbs.)(Kg.)	Mounting Type (Wall)(Floor)	Knockouts (Inches)(Cm.)	Optional Electrostatic Shield	Wiring Diagrams	Design Figures
3.0	T3003K0011SCH	11.83 (30.0)	14.17 (36.0)	8.82 (22.4)	140 (63.5)	W	0.75-1.25 (1.9-3.2)	STD.	21	F
6.0	T3006K0011SCH	14.03 (36.0)	17.77 (45.1)	11.52 (29.3)	180 (81.6)	W	0.75-1.25 (1.9-3.2)	STD.	21	F
9.0	T3009K0011SCH	18.86 (48.0)	20.30 (51.6)	9.03 (22.9)	250 (113.0)	F ①	NA	STD.	21	I
15.0	T3015K0013SCH	24.81 (63.0)	27.13 (68.9)	11.14 (28.3)	613 (278.1)	F	NA	STD.	22	I
30.0	T3030K0013SCH	25.31 (64.3)	30.18 (76.7)	12.76 (32.4)	780 (354.0)	F	NA	STD.	22	I
45.0	T3045K0013SCH	26.82 (68.1)	34.68 (88.1)	15.25 (38.7)	1126 (511.0)	F	NA	STD.	22	I

Notes: 3.0 through 45.0 kVA encapsulated (DOE 2016 exempt). For larger kVA sizes, contact us.

① Wall mounting brackets are available for these sizes.

480 DELTA PRIMARY VOLTS — 240 DELTA/120 TAP SECONDARY VOLTS — MAY BE USED ON A 4 WIRE 480Y/277 VOLTS SUPPLY— 3Ø, 60 Hz

kVA	Catalog Number	Height (Inches)(Cm.)	Width (Inches)(Cm.)	Depth (Inches)(Cm.)	Weight (Lbs.)(Kg.)	Mounting Type (Wall)(Floor)	Knockouts (Inches)(Cm.)	Optional Electrostatic Shield	Wiring Diagrams	Design Figures
3.0 ②	T2A533281S	10.38 (26.4)	12.37 (31.4)	7.47 (19.0)	75 (34.0)	W	0.75-1.25 (1.9-3.2)	STD.	25	F
6.0 ②	T2A533291S	11.83 (30.0)	14.17 (36.0)	8.82 (22.4)	140 (63.5)	W	0.75-1.25 (1.9-3.2)	STD.	25	F
9.0 ②	T2A533401S	14.03 (36.0)	17.77 (45.1)	11.52 (29.3)	180 (81.6)	W	0.75-1.25 (1.9-3.2)	STD.	25	F
15.0 ②	T3533411S	18.86 (47.9)	20.30 (51.6)	9.03 (22.9)	250 (113.0)	F ①	NA	STD.	25	I
15.0	T3015K0023B	25.50 (64.8)	24.39 (61.9)	19.37 (49.2)	300 (136.0)	F ①	NA	YES ③	26	E
30.0	T3030K0023B	25.50 (64.8)	24.39 (61.9)	19.37 (49.2)	360 (163.2)	F ①	NA	YES ③	26	E
45.0	T3045K0023B	25.50 (64.8)	24.39 (61.9)	19.37 (49.2)	500 (226.8)	F ①	NA	YES ③	26	E
75.0	T3075K0023B	29.41 (74.7)	28.15 (71.5)	22.37 (56.8)	600 (272.2)	F ①	NA	YES ③	26	E
112.5	T3112K0023B	35.47 (90.1)	31.90 (81.0)	26.88 (68.2)	938 (425.5)	F	NA	YES ③	26	E
150.0	T3150K0023B	41.52 (105.4)	32.90 (83.5)	29.87 (75.9)	1406 (637.8)	F	NA	YES ③	26	E
225.0	T3225K0023B	41.52 (105.4)	32.90 (83.5)	29.87 (75.9)	1500 (680.4)	F	NA	YES ③	26	E
300.0	T3300K0023B	45.60 (115.8)	39.50 (100.3)	35.50 (90.1)	1938 (879.0)	F	NA	YES ③	26	E
500.0	T3500K0023B	57.80 (147.0)	45.60 (115.8)	41.50 (105.4)	3344 (1516.8)	F	NA	YES ③	26	G
750.0	T3750K0023B	62.80 (159.5)	54.00 (137.1)	41.50 (105.4)	4260 (1932.3)	F	NA	YES ③	26	G

Notes: 3.0 kVA through 750.0 kVA provided with 120V lighting tap limited to 5% of nameplate rating.

① Wall mounting brackets are available for these sizes, refer to page 217.

② DOE 2016 exempt, encapsulated unit

③ Add "S" to part number

All Wiring Diagrams begin on page 209.



480 DELTA PRIMARY VOLTS — 480Y/277 SECONDARY VOLTS — MAY BE USED ON A 4 WIRE 480Y/277 VOLTS SUPPLY— 3Ø, 60 Hz

kVA	Catalog Number	Height (Inches)(Cm.)	Width (Inches)(Cm.)	Depth (Inches)(Cm.)	Weight (Lbs.)(Kg.)	Mounting Type (Wall)(Floor)	Knockouts (Inches)(Cm.)	Optional Electrostatic Shield	Wiring Diagrams	Design Figures
15.0 ②	T335000153S	18.86 (48.0)	20.30 (51.6)	9.03 (22.9)	250 (113.0)	F ①	NA	STD.	31	I
15.0	T3015K0053B	25.50 (64.8)	24.39 (61.9)	19.37 (49.2)	300 (136.0)	F ①	NA	YES ③	31	E
30.0	T3030K0053B	25.50 (64.8)	24.39 (61.9)	19.37 (49.2)	360 (163.3)	F ①	NA	YES ③	31	E
45.0	T3045K0053B	25.50 (64.8)	24.39 (61.9)	19.37 (49.2)	500 (226.8)	F ①	NA	YES ③	31	E
75.0	T3075K0053B	29.41 (74.7)	28.15 (71.5)	22.37 (56.8)	600 (272.2)	F ①	NA	YES ③	31	E
112.5	T3112K0053B	35.47 (90.1)	31.90 (81.0)	26.88 (68.2)	888 (402.8)	F	NA	YES ③	31	E
150.0	T3150K0053B	41.52 (105.4)	32.90 (83.5)	29.87 (75.9)	1444 (655.0)	F	NA	YES ③	31	E
225.0	T3225K0053B	41.52 (105.4)	32.90 (83.5)	29.87 (75.9)	1513 (686.3)	F	NA	YES ③	31	E
300.0	T3300K0053B	45.60 (115.8)	39.50 (100.3)	35.50 (90.1)	2000 (907.2)	F	NA	YES ③	31	E

① Wall mounting brackets are available for these sizes, refer to page 217.

② DOE 2016 exempt, encapsulated unit

③ Add "S" to part number

600 DELTA PRIMARY VOLTS — 208Y/120 TAP SECONDARY VOLTS— 3Ø, 60 Hz

kVA	Catalog Number	Height (Inches)(Cm.)	Width (Inches)(Cm.)	Depth (Inches)(Cm.)	Weight (Lbs.)(Kg.)	Mounting Type (Wall)(Floor)	Knockouts (Inches)(Cm.)	Optional Electrostatic Shield	Wiring Diagrams	Design Figures
3.0 ②	T2A793301S	10.38 (26.4)	12.37 (31.4)	7.47 (19.0)	75 (34.0)	W	0.75-1.25 (1.9-3.2)	STD.	28	F
6.0 ②	T2A793311S	11.83 (30.0)	14.17 (36.0)	8.82 (22.4)	140 (63.5)	W	0.75-1.25 (1.9-3.2)	STD.	28	F
9.0 ②	T2A793321S	14.03 (36.0)	17.77 (45.1)	11.52 (29.3)	180 (81.6)	W	0.75-1.25 (1.9-3.2)	STD.	28	F
15.0 ②	T3793331S	18.86 (47.9)	20.30 (51.6)	9.03 (22.9)	250 (113.0)	F ①	NA	STD.	28	I
15.0	T3015K0083BS	25.50 (64.8)	24.39 (61.9)	19.37 (49.2)	300 (136.0)	F ①	NA	STD.	29	E
30.0	T3030K0083BS	25.50 (64.8)	24.39 (61.9)	19.37 (49.2)	360 (163.2)	F ①	NA	STD.	29	E
45.0	T3045K0083BS	25.50 (64.8)	24.39 (61.9)	19.37 (49.2)	500 (226.8)	F ①	NA	STD.	29	E
75.0	T3075K0083BS	29.41 (74.7)	28.15 (71.5)	22.37 (56.8)	600 (272.2)	F ①	NA	STD.	29	E
112.5	T3112K0083BS	35.47 (90.1)	31.90 (81.0)	26.88 (68.2)	938 (425.5)	F	NA	STD.	29	E
150.0	T3150K0083BS	41.52 (105.4)	32.90 (83.5)	29.87 (75.9)	1213 (550.2)	F	NA	STD.	29	E
225.0	T3225K0083BS	41.52 (105.4)	32.90 (83.5)	29.87 (75.9)	1500 (680.4)	F	NA	STD.	29	E
300.0	T3300K0083BS	45.60 (115.8)	39.50 (100.3)	35.50 (90.1)	1938 (879.0)	F	NA	STD.	29	E
500.0	T3500K0083BS	57.80 (147.0)	45.60 (115.8)	41.50 (105.4)	3344 (1516.8)	F	NA	STD.	29	G
750.0	T3750K0083BS	62.80 (159.5)	54.00 (137.1)	41.50 (105.4)	4260 (1932.3)	F	NA	STD.	29	G

① Wall mounting brackets are available for these sizes, refer to page 217.

② DOE 2016 exempt, encapsulated unit

All Wiring Diagrams begin on page 209.



600 DELTA PRIMARY VOLTS — 240 DELTA/120 TAP SECONDARY VOLTS — 3Ø, 60 Hz

kVA	Catalog Number	Height (Inches)(Cm.)	Width (Inches)(Cm.)	Depth (Inches)(Cm.)	Weight (Lbs.)(Kg.)	Mounting Type (Wall)(Floor)	Knockouts (Inches)(Cm.)	Optional Electrostatic Shield	Wiring Diagrams	Design Figures
15.0	T3015K0323BS	25.50 (64.8)	24.39 (61.9)	19.37 (49.2)	300 (136.0)	F ①	NA	STD.	69	E
30.0	T3030K0323BS	25.50 (64.8)	24.39 (61.9)	19.37 (49.2)	360 (163.3)	F ①	NA	STD.	69	E
45.0	T3045K0323BS	25.50 (64.8)	24.39 (61.9)	19.37 (49.2)	500 (226.8)	F ①	NA	STD.	69	E
75.0	T3075K0323BS	29.41 (74.7)	28.15 (71.5)	22.37 (56.8)	600 (272.2)	F ①	NA	STD.	69	E

① Wall mounting brackets are available for these sizes, refer to page 217.

600 DELTA PRIMARY VOLTS — 480Y/277 TAP SECONDARY VOLTS — 3Ø, 60 Hz

kVA	Catalog Number	Height (Inches)(Cm.)	Width (Inches)(Cm.)	Depth (Inches)(Cm.)	Weight (Lbs.)(Kg.)	Mounting Type (Wall)(Floor)	Knockouts (Inches)(Cm.)	Optional Electrostatic Shield	Wiring Diagrams	Design Figures
3.0 ②	T2A795161S	10.38 (26.4)	12.37 (31.4)	7.47 (19.0)	75 (34.0)	W	0.75-1.25 (1.9-3.2)	STD.	55	F
6.0 ②	T2A795171S	11.83 (30.0)	14.17 (36.0)	8.82 (22.4)	140 (63.5)	W	0.75-1.25 (1.9-3.2)	STD.	55	F
9.0 ②	T2A795181S	14.03 (38.8)	17.77 (45.1)	11.52 (29.3)	180 (81.6)	W	0.75-1.25 (1.9-3.2)	STD.	55	F
15.0 ②	T3795191S	18.86 (47.9)	20.30 (51.6)	9.03 (22.9)	250 (113.0)	F ①	NA	STD.	55	I
15.0	T3015K0093BS	25.50 (64.8)	24.39 (61.9)	19.37 (49.2)	300 (136.0)	F ①	NA	STD.	51	E
30.0	T3030K0093BS	25.50 (64.8)	24.39 (61.9)	19.37 (49.2)	360 (163.3)	F ①	NA	STD.	51	E
45.0	T3045K0093BS	25.50 (64.8)	24.39 (61.9)	19.37 (49.2)	500 (226.8)	F ①	NA	STD.	51	E
75.0	T3075K0093BS	29.41 (74.7)	28.15 (71.5)	22.37 (56.8)	600 (272.2)	F ①	NA	STD.	51	E
112.5	T3112K0093BS	35.47 (90.1)	31.90 (81.0)	26.88 (68.2)	938 (425.5)	F	NA	STD.	51	E
150.0	T3150K0093BS	41.52 (105.4)	32.90 (83.5)	29.87 (75.9)	1406 (637.8)	F	NA	STD.	51	E

① Wall mounting brackets are available for these sizes, refer to page 217.

② DOE 2016 exempt, encapsulated unit

All Wiring Diagrams begin on page 209.



600 PRIMARY VOLTS — 480 SECONDARY VOLTS — 3Ø, 60 Hz
480 PRIMARY VOLTS — 380 SECONDARY VOLTS — 3Ø, 50/60 Hz

AUTO TRANSFORMERS

kVA ①		Catalog Number	Height (Inches)(Cm.)	Width (Inches)(Cm.)	Depth (Inches)(Cm.)	Weight (Lbs.)(Kg.)	Mounting Type (Wall)(Floor)	Knockouts (Inches)(Cm.)	Weather Shield	Wiring Diagrams	Design Figures
Primary 600V Secondary 480V	Primary 480V Secondary 380V										
15.0	12.0	T2527031③	15.21 (38.6)	19.25 (48.9)	7.37 (18.7)	104 (47.2)	W	NA	NA	56	F
30.0	24.0	T2527051③	15.21 (38.6)	19.25 (48.9)	7.37 (18.7)	152 (68.9)	W	NA	NA	56	F
45.0	36.0	T2527071③	15.21 (38.6)	19.25 (48.9)	7.37 (18.7)	156 (70.8)	W	NA	NA	56	F
75.0	60.0	T3527101③	18.86 (47.9)	20.30 (51.6)	9.03 (22.9)	300 (136.1)	F ⑤	NA	NA	56	I
112.5	90.0	T2A527121④	25.50 (64.8)	24.40 (62.0)	19.40 (49.3)	325 (147.0)	F ①	NA	WSA1	57	E
150.0	120.0	T2A527131④	25.50 (64.8)	24.40 (62.0)	19.40 (49.3)	350 (158.8)	F ①	NA	WSA1	57	E
225.0	180.0	T2A527151④	29.41 (74.7)	28.15 (71.5)	22.37 (56.8)	600 (272.0)	F ①	NA	WSA2	57	E
300.0	240.0	T2A527171④	29.41 (74.7)	28.15 (71.5)	22.37 (56.8)	650 (294.8)	F	NA	WSA2	57	E
450.0	360.0	T2A527181④	35.47 (90.1)	31.90 (81.0)	26.88 (68.3)	750 (340.0)	F	NA	WSA3	57	E
500.0	400.0	T2A527191④	35.47 (90.1)	31.90 (81.0)	26.88 (68.3)	790 (358.3)	F	NA	WSA3	57	E

Notes: Autotransformer DOE 2106 exempt

① Wall mounting brackets are available for these sizes, refer to page 217.

② If used on unbalanced loads, these units should only be used on a 4 wire system with the supply neutral connected to the transformer. If used on balanced loads, such as motor loads, then they may be used on a 3 wire system without a neutral or 4th wire.

③ These units are encapsulated with a 115° C temperature rise.

④ These units are ventilated with 150° C temperature rise.

⑤ Wall mounting brackets use PL-79912

All Wiring Diagrams begin on page 209.

ECONOMICAL AUTO ARRANGEMENTS

480 PRIMARY (open delta) VOLTS —
240 SECONDARY (open delta) VOLTS — 3Ø, 60 Hz **THREE PHASE**

kVA ①	Quantity ②	Catalog Number ③	Primary Full Load Amps	Secondary Full Load Amps	Maximum Size Fuse or Breaker
3.0	2	T253010S	3.60	7.20	10
5.0	2	T253011S	6.00	12.00	10
6.0	2	T253012S	7.20	14.40	15
10.0	2	T2530134S	12.00	24.00	15
17.0	2	T2530144S	20.50	40.80	30
26.0	2	T2535153S	31.50	63.00	40
34.0	2	T2535163S	41.00	81.60	60
52.0	2	T2535173S	63.00	125.00	80
86.0	2	T2535183S	104.00	206.30	150
130.5	2	TP530193S	157.00	314.00	200
173.0	2	TP530203S	209.00	418.00	300
259.0	2	TP530213S	312.00	623.00	400
346.0	2	TP530223S	417.00	834.00	600
578.0	2	TP530233S	696.00	1392.00	1000
865.0	2	TP530243S	1041.00	2082.00	1600

① kVA capacity of three phase autotransformer bank, using two single phase, 60 Hz transformers connected open delta

② Catalog No. is for 1 transformer, 2 units are required.

③ Can be reverse connected with no change in kVA.

④ For transformer dimensions, refer to appropriate table in section 1, page 23.

⑤ For proper overcurrent protection, refer to Article 450-4 of N.E.C.

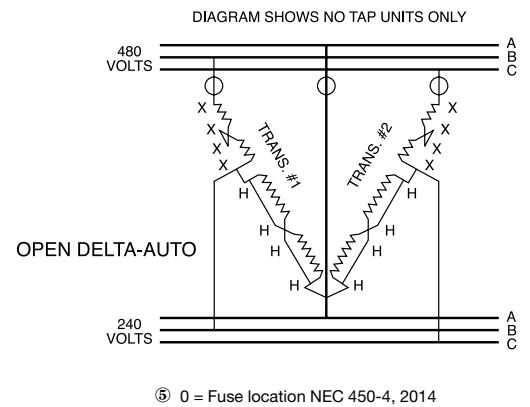

The diagram is for illustration purposes only. Please contact the factory for construction details. Each Acme transformer is shipped with detailed wiring diagrams. Refer to nameplate located inside the front cover for specific voltage tap combinations.

600 PRIMARY VOLTS — 480 SECONDARY (open delta) VOLTS — 3Ø, 60 Hz
480 PRIMARY VOLTS — 380 SECONDARY (open delta) VOLTS — 3Ø, 50/60 Hz

THREE PHASE

Primary 600V Secondary 480V kVA ①	Primary Amps	Secondary Amps	Primary 480V Secondary 380V kVA ①	Primary Amps	Secondary Amps	Quantity ②	Catalog Number ③	Maximum Size Fuse or Breaker
8.0	7.70	9.60	6.5	7.80	9.60	2	T253010S	15
12.0	11.55	14.40	9.5	11.55	14.40	2	T253011S	15
17.0	16.33	20.41	13.5	16.33	20.41	2	T253012S	25
25.0	24.06	30.01	20.0	24.06	30.01	2	T2530134S	30
43.0	41.38	51.70	34.0	41.38	51.70	2	T2530144S	60
64.0	61.59	77.00	51.0	61.59	77.00	2	T2535153S	80
86.0	82.76	103.44	68.0	82.76	103.44	2	T2535163S	110
129.0	124.13	155.20	103.0	124.13	155.20	2	T2535173S	175
216.0	207.85	259.80	172.0	207.85	259.80	2	T2535183S	300
324.0	311.78	389.70	259.0	311.78	389.70	2	TP530193S	400
433.0	416.67	520.83	346.0	416.67	520.83	2	TP530203S	600
650.0	625.00	781.00	519.0	625.00	781.00	2	TP530213S	800
865.0	833.00	1040.00	692.0	833.00	1051.00	2	TP530223S	1200
1445.0	1391.00	1738.00	1156.0	1391.00	1756.00	2	TP530233S	2000
2164.0	2083.00	2602.00	1731.0	2083.00	2629.00	2	TP530243S	3000

① kVA capacity of three phase autotransformer bank, using two single phase, 60 Hz transformers connected open delta.

② Catalog No. is for 1 transformer, 2 units are required.

③ Can be reverse connected with no change in kVA.

④ For transformer dimensions, refer to appropriate table in section 1, page 23.

⑤ For proper overcurrent protection, refer to Article 450-4 of N.E.C

The diagram is for illustration purposes only. Please contact the factory for construction details. Each Acme transformer is shipped with detailed wiring diagrams. Refer to nameplate located inside the front cover for specific voltage tap combinations.

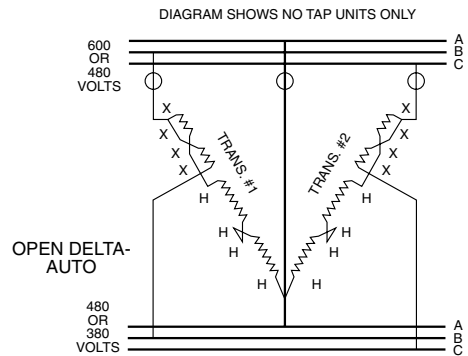

⑤ ○ = Fuse Location NEC 450-4, 2014.

DEVELOPING A NEUTRAL FROM A THREE PHASE, 3-WIRE SUPPLY

PRIMARY (Input): 480 Volts 3Ø, 3 Wire

④ 50/60 Hz

SECONDARY (Output): 480Y/277 Volts 3Ø, 4 Wire

Use 3 Pieces of Type Number ④	Available In	Nameplate kVA For Each Transformer	Number of Transformers Required	Three Phase kVA	Maximum Continuous Amperage Load Per Phase (277 Volts)
T253010S	No Taps Only	1.0	3	10.80	12.50
T253011S	No Taps Only	1.5	3	15.60	18.75
T253012S	No Taps Only	2.0	3	20.70	25.00
T2530134S	Taps & No Taps	3.0	3	31.20	37.50
T2530144S	Taps & No Taps	5.0	3	51.90	62.50
T2535153S	With Taps Only	7.5	3	78.00	93.50
T2535163S	With Taps Only	10.0	3	103.80	125.00
T2535173S	With Taps Only	15.0	3	156.00	187.50
T2535183S	With Taps Only	25.0	3	259.50	312.00
TP530193S	With Taps Only	37.5	3	390.00	468.00
TP530203S	With Taps Only	50.0	3	519.00	625.00
TP530213S	With Taps Only	75.0	3	780.00	935.00
TP530223S	With Taps Only	100.0	3	1038.00	1250.00
TP530233S	With Taps Only	167.0	3	1734.00	2085.00

- ① Applicable for the above connection only.
- ② Connection diagram (using 3 pieces of 1 phase, 60 hertz transformers connected zig-zag auto) for developing a neutral (4th wire) from a 3 phase, 3 wire supply.
- ③ For proper over-current protection, refer to the N.E.C. Article 450-5..
- ④ For transformer dimensions, refer to appropriate table in section 1, page 23.

Each Acme transformer is shipped with detailed wiring diagrams. Refer to nameplate located inside the front cover for specific voltage tap combinations.

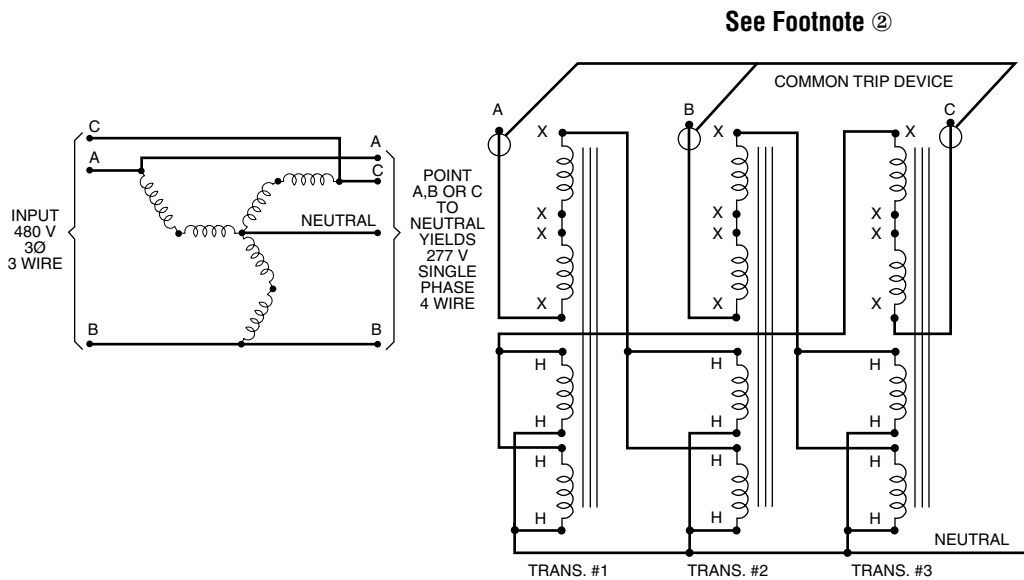

○ = Fuse Location NEC 450-4, 2014. ③

Many non-standard voltage correction problems can be solved by using standard off-the-shelf single phase transformers. Drawings for these products can be downloaded from our website at hubbell-acmeelectric.com. If you don't find the particular combination you are looking for, contact our technical services department for further assistance at 1-800-334-5214.

THREE PHASE

Voltages				
Input	Output	Available kVA Range	Type of Circuit	Acme Drawing Number
208 Delta	208Y/120	3-75	Isolation	A-125879
208 Delta	208Y/120	3-86	Auto Zig-Zag ①	A-125895
208 Delta	240 Delta/120	1.68-25.2	O.D. ISO	A-700314
208 Delta	240 Delta	3-75	Isolation	A-125880
208 Delta	416Y/240	3-75	Isolation	A-700598
208 Delta	416Y/240	112.5-300	Isolation	A-700591
208Y/120	208Y/120	3-75	Isolation	A-125857
208Y/120	374Y/216	22.5-75	Isolation	A-125883
208Y/120	374Y/216	112.5-750	Isolation	A-102730
208Y/120	480Y/277	3-75	Isolation	B-39881 (pg 2)
240 Delta	208Y/120	3-15	Isolation	A-125855
240 Delta	208Y/120	9-15	Isolation	A-102723
240 Delta	208Y/120	22.5-75	Isolation	A-102722-B
240 Delta	208Y/120	112.5-750	Isolation	A-125856
240 Delta	208Y/120	3-75	Isolation	A-125858
240 Delta	240 Delta	3-75	Isolation	A-125859
240 Delta	240Y/138	10.3-258.75	Auto Zig-Zag ①	A-125896
240 Delta	374Y/216	22.5-75	Isolation	A-125881
240 Delta	374Y/216	112.5-750	Isolation	A-125882
240 Delta	480Y/277	3-75	Isolation	B-39881 (pg 1)
380 Delta	240 Delta	3-75	Isolation	A-700592
380 Delta	240 Delta	112.5-300	Isolation	A-700593
380 Delta	228 Delta	1.4-7.0	O.D. Auto	A-35633
380 Delta	228 Delta	4.2-7.0	O.D. Auto	A-125892
380 Delta	228 Delta	10.4-34.5	O.D. Auto	A-125893
380 Delta	228 Delta	51-227	O.D. Auto	A-125894
380 Delta	416Y/240	3-75	Isolation	A-700599
380 Delta	416Y/240	112.5-300	Isolation	A-700594
380Y/220	240 Delta	3-75	Isolation	A-700600
380Y/220	240 Delta	112.5-300	Isolation	A-700595
416Y/240	440 Delta	3-75	Isolation	A-700602
416Y/240	440 Delta	112.5-300	Isolation	A-700597
416 Delta	240 Delta	3-75	Isolation	A-700601
416 Delta	240 Delta	112.5-300	Isolation	A-700596

Voltages				
Input	Output	Available kVA Range	Type of Circuit	Acme Drawing Number
416Y/240	208Y/120	3-15	Isolation	A-700319
416Y/240	208Y/120	22.5-75	Isolation	A-700322
480 Delta	240 Delta/120	1.68-5.04	O.D. ISO Hi-Leg ①	A-125849
480 Delta	240 Delta/120	3.36	O.D. ISO Hi-Leg ①	A-125850
480 Delta	240 Delta/120	5.04	O.D. ISO Hi-Leg ①	A-125851
480 Delta	240 Delta/120	8.4	O.D. ISO Hi-Leg ①	A-125852
480 Delta	240 Delta/120	12.6-25.2	O.D. ISO Hi-Leg ①	A-125853
480 Delta	240 Delta/120	42	O.D. ISO Hi-Leg ①	A-125854
480 Delta	240 Delta/120	63-266	O.D. ISO Hi-Leg ①	A-111702
480 Delta	240 Delta	1.68-8.4	O.D. ISO	A-32817-B
480 Delta	240 Delta	5.04-8.4	O.D. ISO	A-125872
480 Delta	240 Delta	12.6-42	O.D. ISO	A-125873
480 Delta	240 Delta	63-420	O.D. ISO	A-125874
480 Delta	416Y/240	3-15	Isolation	A-125875
480 Delta	416Y/240	9-15	Isolation	A-125876
480 Delta	416Y/240	22.5-75	Isolation	A-125877
480 Delta	416Y/240	112.5-750	Isolation	A-125878
480 Delta	394Y/228	9-15	Isolation	A-125884
480 Delta	394Y/228	22.5-75	Isolation	A-125885
480 Delta	394Y/228	112.5-750	Isolation	A-125886
600 Delta	208Y/120	3-6	Isolation	A-102758
600 Delta	208Y/120	9-75	Isolation	A-125863
600 Delta	208Y/120	112.5-500	Isolation	A-125864
600 Delta	240 Delta	3-6	Isolation	A-125860
600 Delta	240 Delta	9-75	Isolation	A-125861
600 Delta	240 Delta	112.5-500	Isolation	A-125862
600 Delta	240 Delta/120	1.68-2.52	O.D. ISO Hi-Leg ①	A-125865
600 Delta	240 Delta/120	3.36	O.D. ISO Hi-Leg ①	A-125866
600 Delta	240 Delta/120	5.04-25.2	O.D. ISO Hi-Leg ①	A-125867
600 Delta	240 Delta/120	42	O.D. ISO Hi-Leg ①	A-125868
600 Delta	240 Delta/120	63-168	O.D. ISO Hi-Leg ①	A-125869
600 Delta	240 Delta	1.68-3.36	O.D. ISO	A-33227-A
600 Delta	240 Delta	5.04-42	O.D. ISO	A-125870
600 Delta	240 Delta	63-280	O.D. ISO	A-125871

KEY

O.D. — Open Delta

ISO — Isolation

AUTO — Autotransformer

① Cannot Be Reverse Connected